

GUMMIFEDERELEMENT TYP LTB-S

RUBBER SUSPENSION UNIT TYPE LTB-S



RESATEC GUMMIFEDERELEMENT TYP LTB-S:

Das Innenprofil Typ S ermöglicht eine Steckverbindung. Die Einstecktiefe des gesteckten Vierkantes soll mindestens dem 1,8-fachen des Materialquerschnittes (Mass S) entsprechen. Als Vierkant soll ein blanker Stahl mit der Toleranz h11 und facettierten Kanten verwendet werden. Das Aussengehäuse kann durch die Befestigungslöcher in der Flanschpartie direkt mit Schrauben der Qualität 8,8 befestigt werden. Eine wechselseitige Auslenkung über die Element-Nulllage ist nicht möglich.

RESATEC RUBBER SUSPENSION UNIT TYPE LTB-S:

The inner profile type S enables a plug-in connection. The insertion depth of the inserted square should be at least 1.8 times the material cross-section (dimension S). The square should be made of bright steel with tolerance h11 and faceted edges. The outer housing can be fastened directly with quality 8.8 screws through the fastening holes in the flange section. An alternating deflection over the element zero position is not possible.

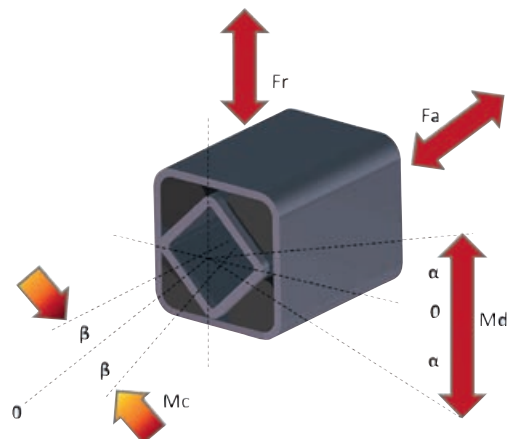
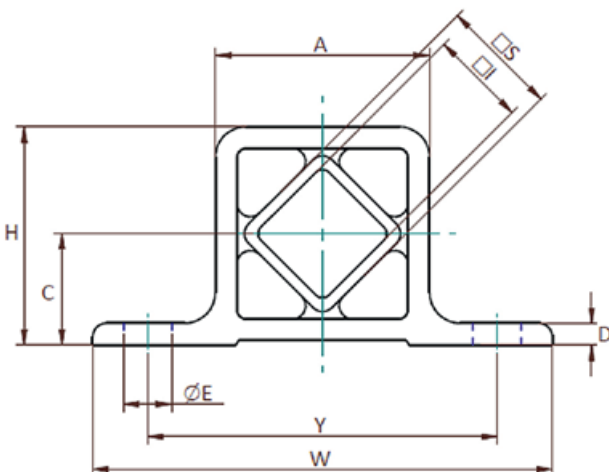

Typ type	Art. Nr. art. no.	A	C	D	E	øE	øF	H	□I	L	LN	□S	W	Y	Gewicht weight kg	Material																											
		mm	mm	mm	mm	mm	mm	mm	mm	mm	mm	mm	mm	mm		mm	Außenprofil outer profile	Innenrohr/core square tube	Gummi rubber																								
LTB-S 3 – 40	561 430 40	27	15	4	–	7	–	30	11	45	40	15	65	50	2.18	SINT-C 40	Stahl S235JR/galvanisch verzinkt steel S235JR/galvanized	Basis auf SBR/Mischung Code C SBR based/mixture code C																									
LTB-S 5 – 40	561 450 40				–					45	40				0.24	Aluminium																											
LTB-S 5 – 60	561 450 60	49	25.5	5	–	11	–	50	22	65	60	27	105	80	0.35																												
LTB-S 5 – 100	561 451 00				60					105	100				0.57																												
LTB-S 6 – 60	561 460 60				–		–			70	60				0.65																												
LTB-S 6 – 80	561 460 80	66	34	6	40	13		67	30	90	80	38	125	100	0.83																												
LTB-S 6 – 120	561 461 20				80					130	120				1.24																												
LTB-S 7 – 80	561 470 80				40		–			90	80				1.2																												
LTB-S 7 – 100	561 471 00	80	38.4	8	65	13		77	35	110	100	45	145	115	1.49																												
LTB-S 7 – 150	561 471 50				2×60					160	150				2.18																												
LTB-S 8 – 120	561 481 20				60					130	120				2.55																												
LTB-S 8 – 160	561 481 60				2×60					170	160				3.35																												
LTB-S 8 – 200	561 482 00	80	45	13	2×70	17	38	90	40	210	200	50	170	130	4.23																												
LTB-S 8 – 240	561 482 40				3×60					250	240				5.03																												
LTB-S 8 – 320	561 483 20				4×60					330	320				6.78																												

Leistungsparameter/performance parameters

Typ type	Art. Nr. art. no.	MC@β +/-1°	Drehmoment und max. Erregerfrequenz bei Winkel α Torque and max. excitation frequency at angle α																			
			Radial		Axial		α +/- 4°		α +/- 8°		α +/- 12°		α +/- 16°		α +/- 20°		α +/- 24°		α +/- 28°		α +/- 32°	
			Federweg deflection	Belastung load	Federweg deflection	Belastung load	Nm	min ⁻¹	Nm	min ⁻¹	Nm	min ⁻¹	Nm	min ⁻¹	Nm	min ⁻¹	Nm	min ⁻¹	Nm	min ⁻¹	Nm	min ⁻¹
LTB-S 3 – 40	561 430 40	2	Sr mm	Fr N	Sa mm	Fa N	1	1 100	2.2	330	3.5	190	5.1	120	7	72	9.2	46	11.7	33	14.7	10
LTB-S 5 – 40	561 450 40	3.99		888		217	4.01		8.22		13.1		19.2		27		37		49.7		65.5	
LTB-S 5 – 60	561 450 60	12.01	0.5	1 333	0.5	325	6.02	900	12.4	300	19.8	170	29	110	40.9	68	56.2	43	75.6	30	100	10
LTB-S 5 – 100	561 451 00	49.9		2 221		542	10		20.6		32.9		48.3		67.9		93.2		125		166	
LTB-S 6 – 60	561 460 60	11.74		1 564		372	11.3		23.7		38.5		56.7		79.6		108		144		188	
LTB-S 6 – 80	561 460 80	25.4	0.5	2 086	0.5	497	15.1	900	31.7	280	51.4	150	75.9	92	107	57	145	38	194	28	253	10
LTB-S 6 – 120	561 461 20	78.3		3 130		745	22.6		47.5		77.1		114		160		218		291		380	
LTB-S 7 – 80	561 470 80	27		2 196		536	22.7		47.1		75.3		110		152		206		272		353	
LTB-S 7 – 100	561 471 00	52.2	0.5	2 745	0.5	669	28.4	850	58.9	250	94.1	150	137	86	190	57	256	36	338	26	439	10
LTB-S 7 – 150	561 471 50	135		4 063		991	42.1		87.8		141		206		286		385		508		658	
LTB-S 8 – 120	561 481 20	89.5		3 442		840	72.9		139.5		209		289		390		519		685		898	
LTB-S 8 – 160	561 481 60	115.8		4 617		1 126	97.8		187.2		280		388		523		696		920		1 206	
LTB-S 8 – 200	561 482 00	288	0.5	5 772	0.5	1 408	122.2	840	234	250	350	150	485	85	654	53	870	36	1 150	24	1 506	10
LTB-S 8 – 240	561 482 40	605		6 919		1 688	146.5		281		420		582		784		1 044		1 379		1 807	
LTB-S 8 – 320	561 483 20	1 677		9 231		2 252	195.4		374		560		776		1 046		1 393		1 840		2 411	



RESATEC AG
ROSENWEG 1
CH-5037 MUHEN

+41 62 723 27 24
INFO@RESATEC.CH
WWW.RESATEC.CH