

# GUMMIFEDERELEMENT TYP LTD-C

## RUBBER SUSPENSION UNIT TYPE LTD-C

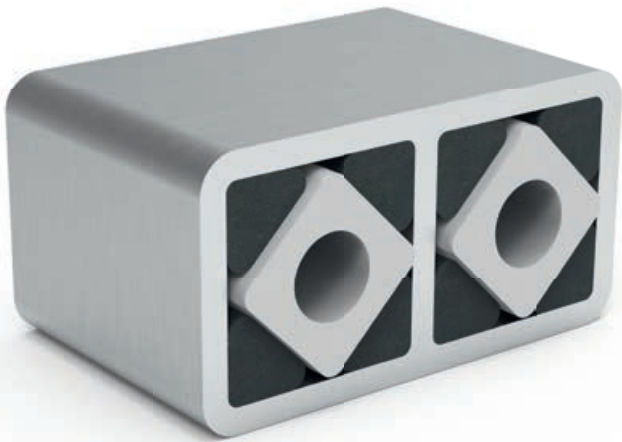

### RESATEC GUMMIFEDERELEMENT TYP LTD-C:

Das Innenprofil Typ C ermöglicht die Befestigung mit zentraler Schraube. Es sind Schrauben der Qualität 8,8 zu verwenden. Das Doppelement wird zur Realisierung von Serie- oder Parallelschaltungen verwendet. Nur auf Anfrage verfügbar.

### RESATEC RUBBER SUSPENSION UNIT TYPE LTD-C:

The inner profile type C enables fastening with central screw. Screws of quality 8.8 must be used. The double element is used for the realization of series or parallel circuits. Only available on request.

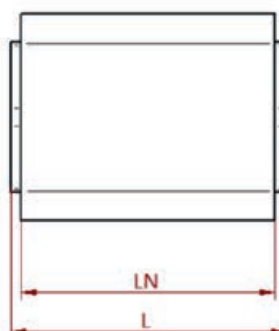
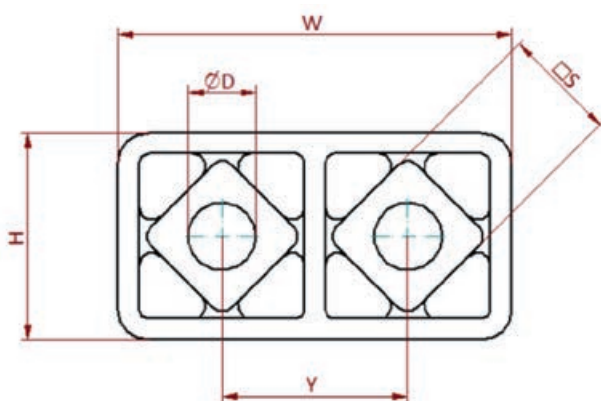

Abmasse/Material/dimensions/material

Typ type	Art. Nr. art. no.	øD +0,5 0 mm	H mm	L mm	LN mm	□S mm	W mm	Y mm	Gewicht weight kg	Material		
										Aussenprofil outer profile	Innenprofil core profile	Gummi rubber
LTD-C 5 – 40	562 650 40			45	40				0.34	Aluminium	Aluminium	Basis auf SBR /Mischung Code C SBR based /mixture code C
LTD-C 5 – 60	562 650 60	16	49	65	60	27	93	45	0.50			
LTD-C 5 – 100	562 651 00			105	100				0.83			
LTD-C 6 – 60	562 660 60			70	60				0.95			
LTD-C 6 – 80	562 660 80	20	66	90	80	38	126	60	1.25			
LTD-C 6 – 120	562 661 20			130	120				1.84			

Leistungsparameter/performance parameters

Typ type	Art. Nr. art. no.	MC @ β +/-1° Nm	Radial		Axial		Drehmoment und max. Erregerfrequenz bei Winkel α Torque and max. excitation frequency at angle α															
			Federweg deflection	Belastung load	Federweg deflection	Belastung load	α +/- 4°		α +/- 8°		α +/- 12°		α +/- 16°		α +/- 20°		α +/- 24°		α +/- 28°		α +/- 32°	
			Sr mm	Fr N	Sa mm	Fa N	Nm	min <sup>-1</sup>	Nm	min <sup>-1</sup>	Nm	min <sup>-1</sup>	Nm	min <sup>-1</sup>	Nm	min <sup>-1</sup>	Nm	min <sup>-1</sup>	Nm	min <sup>-1</sup>	Nm	min <sup>-1</sup>
LTD-C 5 – 40	562 650 40	3.99		888		217	4.01		8.22		13.1		19.2		27		37		49.7		65.5	
LTD-C 5 – 60	562 650 60	12.01	0.5	1'333	0.5	325	6.02	990	12.4	300	19.8	170	29	110	40.9	68	56.2	43	75.6	30	100	10
LTD-C 5 – 100	562 651 00	49.9		2'221		542	10		20.6		32.9		48.3		67.9		93.2		125		166	
LTD-C 6 – 60	562 660 60	11.74		1'564		372	11.3		23.7		38.5		56.7		79.6		108		144		188	
LTD-C 6 – 80	562 660 80	25.4	0.5	2'086	0.5	497	15.1	900	31.7	280	51.4	150	75.9	92	107	57	145	38	194	28	253	10
LTD-C 6 – 120	562 661 20	78.3		3'130		745	22.6		47.5		77.1		114		160		218		291		380	



**RESATEC AG**  
**ROSENWEG 1**  
**CH-5037 MUHEN**

**+41 62 723 27 24**  
**INFO@RESATEC.CH**  
**WWW.RESATEC.CH**

