

GUMMIFEDERELEMENTE

RUBBER SUSPENSION UNITS

LTA/LTC/LTS

LTB-A/LTB-C/LTB-S

LTK-A/LTK-C/LTK-S

LTD-A/LTD-C/LTD-S

A

C

S

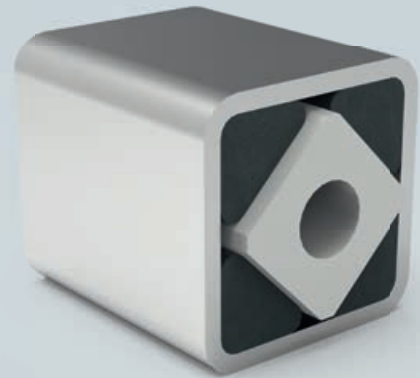

LTC



LTB-A

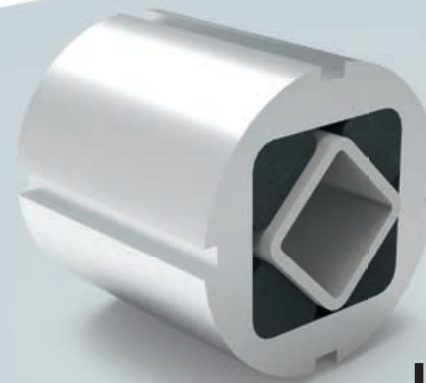

LTK-S

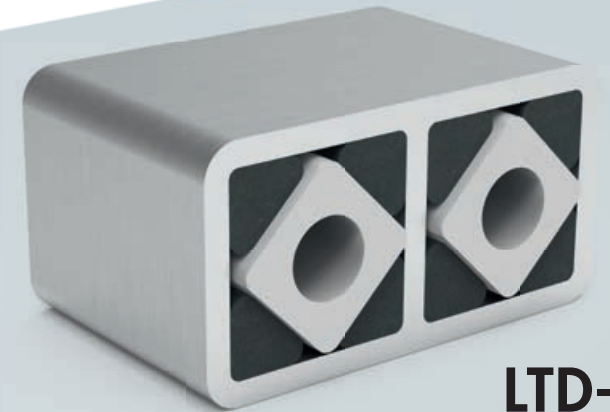

LTD-C



MA

MONTAGEWINKEL
MOUNTING BRACKET
MA



CK



MS

MONTAGEBRIDE
MOUNTING BRACKET
CK/MS

GUMMIFEDERELEMENT TYP LTA

RUBBER SUSPENSION UNIT TYPE LTA



RESATEC GUMMIFEDERELEMENT TYP LTA:

Das Innenprofil Typ A ermöglicht die Befestigung mit Schrauben. Bis zum Typ LTA 7 sind durchgehende Schrauben der Qualität 8,8 zu verwenden. Ab dem Typ LTA 8 sind im Innenprofil Gewinde vorhanden. Eine weitere einfache Einbaumöglichkeit bietet der RESATEC *Montagewinkel Typ MA*. Aussen wird das Gummifeder-element in ein Futterrohr gesteckt oder mit der RESATEC *Montagebride MS* befestigt. Für wechselseitige Auslenkung über die Element-Nulllage geeignet.

RESATEC RUBBER SUSPENSION UNIT TYPE LTA:

The inner profile type A enables fastening with screws. Up to type LTA 7, through screws of quality 8.8 must be used. From type LTA 8 on, there are threads in the inner profile. Another simple installation option is the RESATEC *mounting bracket type MA*. On the outside, the rubber spring element is inserted into a sleeve tube or fastened with the RESATEC *mounting bracket MS*. Suitable for alternating deflection over the element zero position.



PASSENDE MONTAGEHALTERUNG TYP MS/MA
SEITE 38

MATCHING MOUNTING BRACKET TYPE MS/MA
PAGE 38

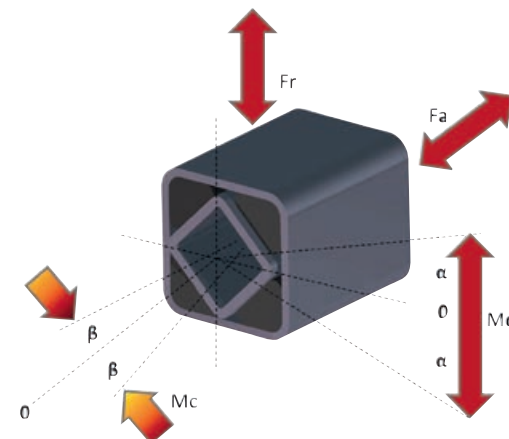
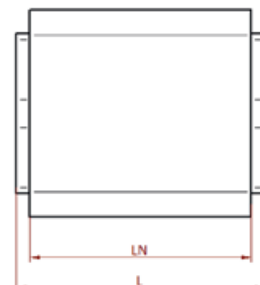
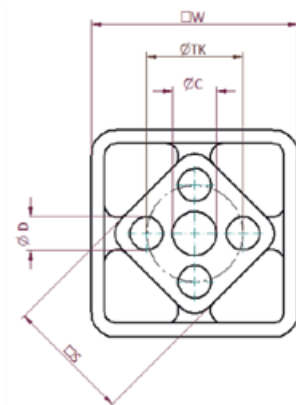

Abmasse/Material/dimensions/material

Typ type	Art. Nr. art. no.	□W mm	□S mm	LN mm	L mm	øTK mm	øD mm	øC mm	Anzahl Briden no. of mounting brackets	Gewicht weight kg	Material		
											Aussenrohr outer square tube	Innenprofil core profile	Gummi rubber
											Stahl S235JR/galvanisch verzinkt steel S235JR/galvanized	Aluminium	Basis auf SBR/Mischung Code C SBR based/mixture code C
LTA 4 – 30	560 540 30			30	35					0.1			
LTA 4 – 50	560 540 50	32	18	50	55	12	6	–	1	0.16			
LTA 4 – 80	560 540 80			80	85					0.25			
LTA 5 – 40	560 550 40			40	45				1	0.24			
LTA 5 – 60	560 550 60	45	27	60	65	20	8	–	1	0.36			
LTA 5 – 100	560 551 00			100	105				2	0.6			
LTA 6 – 60	560 560 60			60	70				1	0.59			
LTA 6 – 80	560 560 80	60	38	80	90	25	10	–	1	0.78			
LTA 6 – 120	560 561 20			120	130				2	1.15			
LTA 7 – 80	560 570 80			80	90				1	1.33			
LTA 7 – 100	560 571 00	75	45	100	110	35	12	16.5	2	1.66			
LTA 7 – 150	560 571 50			150	160				3	2.47			
LTA 8 – 120	560 581 20			120	130		M12 × 40		2	2.16			
LTA 8 – 200	560 582 00	80	50	200	210	40		20.5	3	3.66			
LTA 8 – 300	560 583 00			300	310				4	5.54			

Leistungsparameter/performance parameters

Typ type	Art. Nr. art. no.	MC @ β ±1° Nm	Radial		Axial		Drehmoment und max. Erregerfrequenz bei Winkel α Torque and max. excitation frequency at angle α														
			Federweg deflection mm	Belastung load N	Federweg deflection mm	Belastung load N	α +/- 4°	α +/- 8°	α +/- 12°	α +/- 16°	α +/- 20°	α +/- 24°	α +/- 28°	α +/- 32°							
			Sr	Fr	Sa	Fa	Nm min ⁻¹	Nm min ⁻¹	Nm min ⁻¹	Nm min ⁻¹	Nm min ⁻¹	Nm min ⁻¹	Nm min ⁻¹	Nm min ⁻¹							
LTA 4 – 30	560 540 30	1.51	386		92	1.6	3.37	5.38	7.71	10.4	13.6	17.4	21.8								
LTA 4 – 50	560 540 50	6.68	644	0.5	153	2.67	1050	5.64	330	9.07	190	13.1	110	17.9	72	23.6	46	30.4	33	38.4	10
LTA 4 – 80	560 540 80	26.9	1030		245	4.27	9.01	14.5	20.8	28.3	37.3	47.8	60.2								
LTA 5 – 40	560 550 40	3.99	888		217	4.01	8.22	13.1	19.2	27	37	49.7	65.5								
LTA 5 – 60	560 550 60	12.01	1333	0.5	325	6.02	990	12.4	300	19.8	170	29	110	40.9	68	56.2	43	75.6	30	100	10
LTA 5 – 100	560 551 00	49.9	2221		542	10	20.6	32.9	48.3	67.9	93.2	125	166								
LTA 6 – 60	560 560 60	11.74	1564		372	11.3	23.7	38.5	56.7	79.6	108	144	188								
LTA 6 – 80	560 560 80	25.4	2086	0.5	497	15.1	900	31.7	280	51.4	150	75.9	92	107	57	145	38	194	28	253	10
LTA 6 – 120	560 561 20	78.3	3130		745	22.6	47.5	77.1	114	160	218	291	380								
LTA 7 – 80	560 570 80	27	2196		536	22.7	47.1	75.3	110	152	206	272	353								
LTA 7 – 100	560 571 00	52.2	2745	0.5	669	28.4	850	58.9	250	94.1	150	137	86	190	57	256	36	338	26	439	10
LTA 7 – 150	560 571 50	135	4063		991	42.1	87.8	141	206	286	385	508	658								
LTA 8 – 120	560 581 20	81.8	2828		690	37.2	94.2	171	267	382	517	671	844								
LTA 8 – 200	560 582 00	263	5712	0.5	1393	74.6	840	184	250	329	150	509	85	723	53	971	36	1254	24	1570	10
LTA 8 – 300	560 583 00	1235	8458		2063	110.4	272	485	751	1069	1440	1864	2342								

GUMMIFEDERELEMENT TYP LTC

RUBBER SUSPENSION UNIT TYPE LTC



RESATEC GUMMIFEDERELEMENT TYP LTC:

Das Innenprofil Typ C ermöglicht die Befestigung mit zentraler Schraube. Es sind Schrauben der Qualität 8,8 zu verwenden. Aussen wird das Gummifederelement in ein Futterrohr gesteckt oder mit der RESATEC *Montagebride MS* befestigt. Für wechselseitige Auslenkung bis $\pm 10^\circ$ geeignet.

RESATEC RUBBER SUSPENSION UNIT TYPE LTC:

The inner profile type C enables fastening with central screw. Screws of quality 8.8 must be used. On the outside, the rubber suspension unit is inserted into a sleeve tube or fastened with the RESATEC *mounting bracket MS*. Suitable for alternating deflection up to $\pm 10^\circ$.

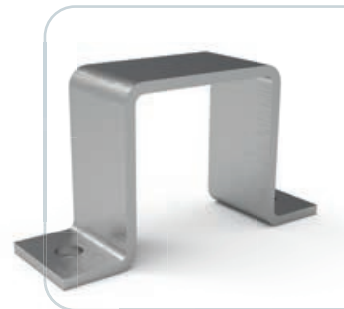

PASSENDEN MONTAGEHALTERUNG TYP MS
SEITE 38

MATCHING MOUNTING BRACKET TYPE MS
PAGE 38

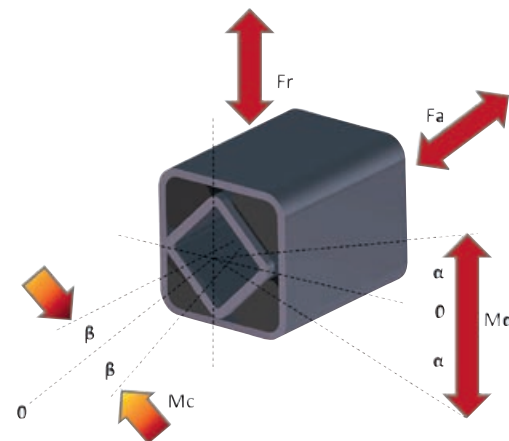
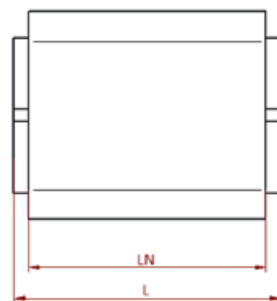
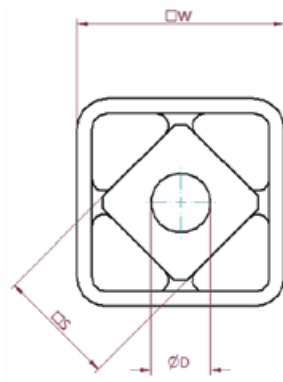

Abmasse/Material/dimensions/material

Typ type	Art. Nr. art. no.	□W mm	□S mm	LN mm	L mm	ØD mm. +0.5 0	Anzahl Briden no. of mounting brackets Typ/type MS	Gewicht weight kg	Material		
									Aussenrohr outer square tube	Innenprofil core profile	Gummi rubber
LTC 5 – 40	560 150 40			40	45		1	0.24	Stahl S235JR/galvanisch verzinkt steel S235JR/galvanized	Aluminium	Basis auf SBR/Mischung Code C SBR based/mixture code C
LTC 5 – 60	560 150 60	45	27	60	65	6	1	0.36			
LTC 5 – 100	560 151 00			100	105		2	0.59			
LTC 6 – 60	560 160 60			60	70		1	0.59			
LTC 6 – 80	560 160 80	60	38	80	90	8	1	0.77			
LTC 6 – 120	560 161 20			120	130		2	1.14			

Leistungsparameter/performance parameters

Typ type	Art. Nr. art. no.	MC @ β ±1° Nm	Radial		Axial		Drehmoment und max. Erregerfrequenz bei Winkel α Torque and max. excitation frequency at angle α															
			Federweg deflection mm	Belastung load N	Federweg deflection mm	Belastung load N	α +/- 4°		α +/- 8°		α +/- 12°		α +/- 16°		α +/- 20°		α +/- 24°		α +/- 28°		α +/- 32°	
			Sr	Fr	So	Fa	Nm	min ⁻¹	Nm	min ⁻¹	Nm	min ⁻¹	Nm	min ⁻¹	Nm	min ⁻¹	Nm	min ⁻¹	Nm	min ⁻¹	Nm	min ⁻¹
LTC 5 – 40	560 150 40	3.99		888		217	4.01		8.22		13.1		19.2		27		37		49.7		65.5	
LTC 5 – 60	560 150 60	12.01	0.5	1 333	0.5	325	6.02	990	12.4	300	19.8	170	29	110	40.9	68	56.2	43	75.6	30	100	10
LTC 5 – 100	560 151 00	49.9		2 221		542	10		20.6		32.9		48.3		67.9		93.2		125		166	
LTC 6 – 60	560 160 60	11.74		1 564		372	11.3		23.7		38.5		56.7		79.6		108		144		188	
LTC 6 – 80	560 160 80	25.4	0.5	2 086	0.5	497	15.1	900	31.7	280	51.4	150	75.4	92	107	57	145	38	194	28	253	10
LTC 6 – 120	560 161 20	78.3		3 130		745	22.6		47.5		77.1		114		160		218		291		380	

GUMMIFEDERELEMENT TYP LTS

RUBBER SUSPENSION UNIT TYPE LTS



RESATEC GUMMIFEDERELEMENT TYP LTS:

Das Innenprofil Typ S ermöglicht eine Steckverbindung. Die Einstecktiefe des gesteckten Vierkantes soll mindestens dem 1,8-fachen des Materialquerschnittes (Mass S) entsprechen. Als Vierkant soll ein blanker Stahl mit der Toleranz h11 und facettierten Kanten verwendet werden. Aussen wird das Element in ein Futterrohr gesteckt oder mit der RESATEC-Montagebride Typ MS befestigt. Eine wechselseitige Auslenkung über die Element-Nulllage ist nicht möglich.

RESATEC RUBBER SUSPENSION UNIT TYPE LTS:

The inner profile type S enables a plug-in connection. The insertion depth of the inserted square should be at least 1.8 times the material cross-section (dimension S). The square should be made of bright steel with tolerance h11 and faceted edges. On the outside, the element is inserted into a sleeve tube or fastened with the RESATEC mounting bracket type MS. An alternating deflection over the element zero position is not possible.

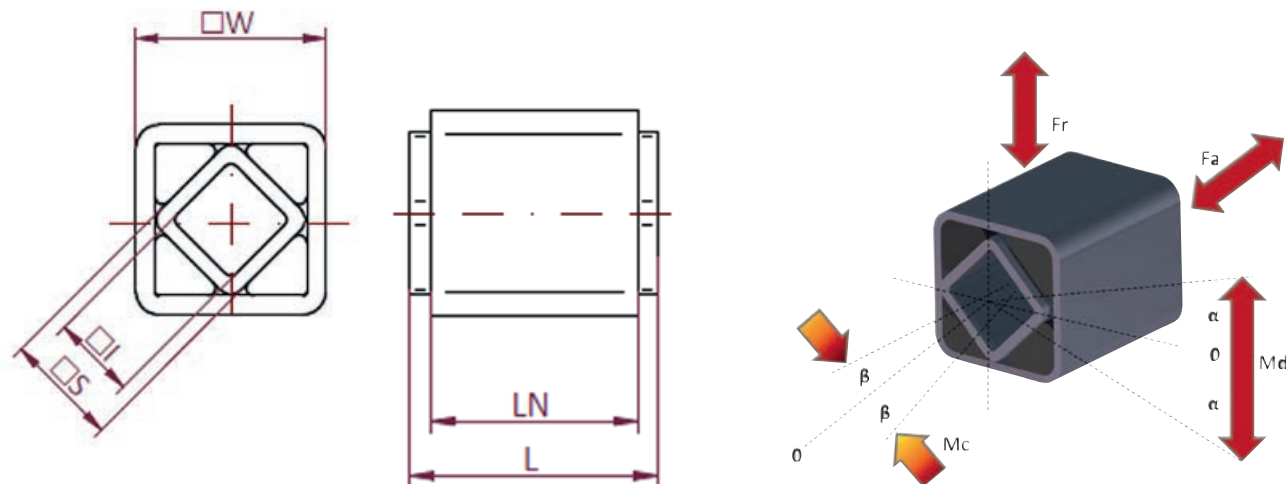

Abmasse/Material/dimensions/material

Typ type	Art. Nr. art. no.	□W mm	□S mm	LN mm	L mm	□I mm	Anzahl Briden no. of mounting brackets Typ/type MS	Gewicht weight kg	Material		
									Aussenrohr outer square tube	Innenprofil core profile	Gummi rubber
LTS 2 – 20	560 420 20			20	25			0.03	Stahl S235JR/galvanisch verzinkt steel S235JR/galvanized	Stahl S235JR/galvanisch verzinkt steel S235JR/galvanized	Basis auf SBR/Mischung Code C SBR based/mixture code C
LTS 2 – 30	560 420 30	20	11	30	35	8	1	0.044			
LTS 2 – 50	560 420 50			50	55			0.071			
LTS 3 – 25	560 430 25			25	30			0.08			
LTS 3 – 40	560 430 40	27	15	40	45	11	1	0.12			
LTS 3 – 60	560 430 60			60	65			0.18			
LTS 4 – 30	560 440 30			30	35			0.11			
LTS 4 – 50	560 440 50	32	18	50	55	12	1	0.18			
LTS 4 – 80	560 440 80			80	85			0.28			
LTS 5 – 40	560 450 40			40	45			0.27			
LTS 5 – 60	560 450 60	45	27	60	65	22	1	0.4			
LTS 5 – 100	560 451 00			100	105		2	0.65			
LTS 6 – 60	560 460 60			60	70			0.66			
LTS 6 – 80	560 460 80	60	38	80	90	30	1	0.86			
LTS 6 – 120	560 461 20			120	130		2	1.27			
LTS 7 – 80	560 470 80			80	90			1.57			
LTS 7 – 100	560 471 00	75	45	100	110	35	2	1.95			
LTS 7 – 150	560 471 50			150	160		3	2.9			
LTS 8 – 120	560 481 20			120	130			2.58			
LTS 8 – 200	560 482 00	80	50	200	210	40	3	4.25			
LTS 8 – 300	560 483 00			300	310		4	6.34			

Leistungsparameter/performance parameters

Typ type	Art. Nr. art. no.	MC @ β 1/2 I ₀ Nm	Radial		Axial		Drehmoment und max. Erregerfrequenz bei Winkel α Torque and max. excitation frequency at angle α															
			Federweg deflection S _r mm	Belastung load F _r N	Federweg deflection S _a mm	Belastung load F _a N	α +/- 4°	α +/- 8°	α +/- 12°	α +/- 16°	α +/- 20°	α +/- 24°	α +/- 28°	α +/- 32°								
			Nm	mm	N	N	Nm	min ⁻¹	Nm	min ⁻¹	Nm	min ⁻¹	Nm	min ⁻¹	Nm	min ⁻¹	Nm	min ⁻¹	Nm	min ⁻¹		
LTS 2 – 20	560 420 20	0.38		246		63		0.33	0.63	0.92	1.26	1.68	2.22	2.92	3.81							
LTS 2 – 30	560 420 30	1.06	0.25	377	0.25	97	0.5	1150	0.97	350	1.48	190	2.11	130	2.95	75	4.05	46	5.51	33	7.4	10
LTS 2 – 50	560 420 50	5.4		624		160		0.83	1.59	2.4	3.38	4.63	6.28	8.43	11.2							
LTS 3 – 25	560 430 25	0.6		214		69		0.6	1.4	2.2	3.2	4.4	5.7	7.3	9.1							
LTS 3 – 40	560 430 40	2	0.25	343	0.25	111	1	1100	2.2	330	3.5	190	5.1	120	7	72	9.2	46	11.7	33	14.7	10
LTS 3 – 60	560 430 60	5.47		513		166		1.5	3.2	5.2	7.5	10.1	13.1	16.5	20.3							
LTS 4 – 30	560 440 30	1.51		386		92		1.6	3.37	5.38	7.71	10.4	13.6	17.4	21.8							
LTS 4 – 50	560 440 50	6.68	0.5	644	0.5	153	2.67	1050	5.64	330	9.07	190	13.1	110	17.9	72	23.6	46	30.4	33	38.4	10
LTS 4 – 80	560 440 80	26.9		1030		245	4.27	9.01	14.5	20.8	28.3	37.3	47.8	60.2								
LTS 5 – 40	560 450 40	3.99		888		217	4.01	8.22	13.1	19.2	27	37	49.7	65.5								
LTS 5 – 60	560 450 60	12.01	0.5	1333	0.5	325	6.02	990	12.4	300	19.8	170	29	110	40.9	68	56.2	43	75.6	30	100	10
LTS 5 – 100	560 451 00	49.9		2221		542	10	20.6	32.9	48.3	67.9	93.2	125	166								
LTS 6 – 60	560 460 60	11.74		1564		372	11.3	23.7	38.5	56.7	79.6	108	144	188								
LTS 6 – 80	560 460 80	25.4	0.5	2086	0.5	497	15.1	900	31.7	280	51.4	150	75.9	92	107	57	145	38	194	28	253	10
LTS 6 – 120	560 461 20	78.3		3130		745	22.6	47.5	77.1	114	160	218	291	380								
LTS 7 – 80	560 470 80	27		2196		536	22.7	47.1	75.3	110	152	206	272	353								
LTS 7 – 100	560 471 00	52.2	0.5	2745	0.5	669	28.4	850	58.9	250	94.1	150	137	86	190	57	256	36	338	26	439	10
LTS 7 – 150	560 471 50	135		4063		991	42.1	87.8	141	206	286	385	508	658								
LTS 8 – 120	560 481 20	81.8		2828		690	37.2	94.2	171	267	382	517	671	844								
LTS 8 – 200	560 482 00	263	0.5	5712	0.5	1393	74.6	840	184	250	329	150	509	85	723	53	971	36	1254	24	1540	10
LTS 8 – 300	560 483 00	1235		8458		2063	110.4	272	485	751	1069	1440	1864	2342								

GUMMIFEDERELEMENT TYP LTB-A

RUBBER SUSPENSION UNIT TYPE LTB-A

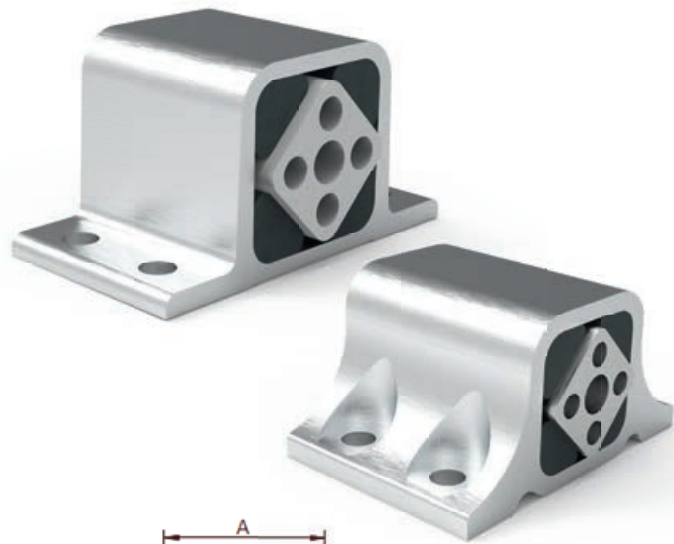

RESATEC GUMMIFEDERELEMENT TYP LTB-A:

Das Innenprofil Typ A ermöglicht die Befestigung mit Schrauben. Bis zum Typ LTB-A 7 sind durchgehende Schrauben der Qualität 8,8 zu verwenden. Ab dem Typ LTB-A 8 sind im Innenprofil Gewinde vorhanden. Eine weitere einfache Einbaumöglichkeit bis zur Grösse LTB-A 8 bietet der RESATEC *Montagewinkel Typ MA*. Das Aussengehäuse kann durch die Befestigungslöcher in der Flanschpartie direkt mit Schrauben der Qualität 8,8 befestigt werden. Für wechselseitige Auslenkung über die Element-Nulllage geeignet.

RESATEC RUBBER SUSPENSION UNIT TYPE LTB-A:

The inner profile type A allows fastening with screws. Up to type LTB-A 7, screws of quality 8.8 must be used. From type LTB-A 8, there are threads in the inner profile. Another simple installation option up to size LTB-A 8 is offered by the RESATEC *mounting bracket type MA*. The outer housing can be fastened directly with quality 8.8 screws through the fastening holes in the flange section. Suitable for alternating deflection over the element zero position.

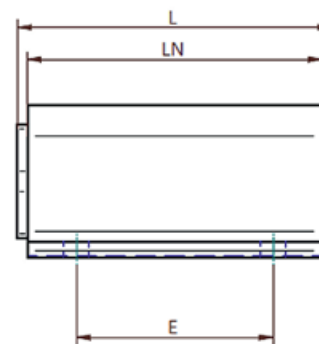
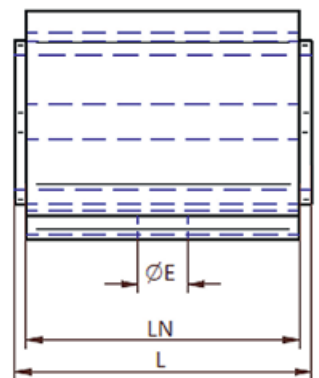
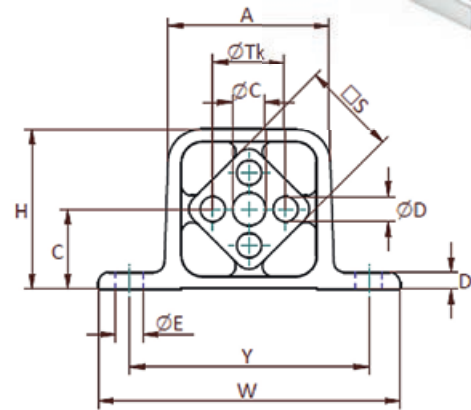

Grösse/size 5/6/7

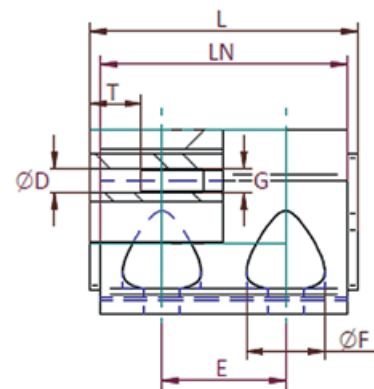

Grösse/size 8



PASSENDE MONTAGEHALTERUNG TYP MA
SEITE 38

MATCHING MOUNTING BRACKET TYPE MA
PAGE 38

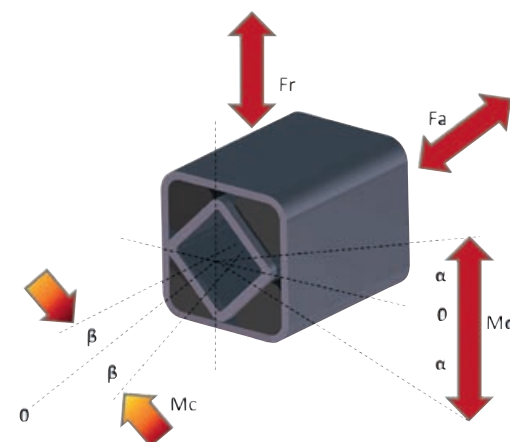

Abmasse/Material/dimensions/material

Typ type	Art. Nr. art. no.	A	C	aC	D	øD	E	øE	øF	G	H	L	LN	S	øTk	T	W	Y	Gewicht weight	
		mm	mm	mm	mm	mm	mm	mm	mm	mm	mm	mm	mm	mm	mm	mm	mm	mm	mm	kg
LTB-A 5 – 40	561 550 40						–					45	40							0.21
LTB-A 5 – 60	561 550 60	49	25.5	–	5	8	–	11	–	–	50	65	60	27	20					0.32
LTB-A 5 – 100	561 551 00						60					105	100							0.51
LTB-A 6 – 60	561 560 60						–					70	60							0.59
LTB-A 6 – 80	561 560 80	66	34	–	6	10	40	13	–	–	67	90	80	38	25					0.75
LTB-A 6 – 120	561 561 20						80					130	120							1.12
LTB-A 7 – 80	561 570 80						40					90	80							0.96
LTB-A 7 – 100	561 571 00	80	38.5	16.5	8	12	65	13	–	–	77	110	100	45	35					1.20
LTB-A 7 – 150	561 571 50						2×60					160	150							1.75
LTB-A 8 – 120	561 581 20						60					130	120							2.24
LTB-A 8 – 160	561 581 60						2×60					170	160							2.96
LTB-A 8 – 200	561 582 00	90	45	20.5	13	12.25	2×70	17	38	MT2 × 30	90	210	200	50	40	25	170	130		3.75
LTB-A 8 – 240	561 582 40						3×60					250	240							4.47
LTB-A 8 – 320	561 583 20						4×60					330	320							6.06

Material

Aussenprofil: Aluminium
Innenprofil: Aluminium
Gummi: Basis auf SBR/Mischung Code C

Material

outer profile: Aluminium
core profile: Aluminium
rubber: SBR based/mixture code C

Leistungsparameter/performance parameters

Typ type	Art. Nr. art. no.	MC @ β ±1°	Radial		Axial		Drehmoment und max. Erregerfrequenz bei Winkel α Torque and max. excitation frequency at angle α															
			Federweg deflection	Belastung load	Federweg deflection	Belastung load	α +/- 4°	α +/- 8°	α +/- 12°	α +/- 16°	α +/- 20°	α +/- 24°	α +/- 28°	α +/- 32°								
		Nm	Sr mm	Fr N	Sa mm	Fa N	Nm	min ⁻¹	Nm	min ⁻¹	Nm	min ⁻¹	Nm	min ⁻¹	Nm	min ⁻¹	Nm	min ⁻¹	Nm	min ⁻¹		
LTB-A 5 – 40	561 550 40	3.99		888		217	4.01		8.22		13.1		19.2		27		37		49.7		65.5	
LTB-A 5 – 60	561 550 60	12.01	0.5	1333	0.5	325	6.02	990	12.4	300	19.8	170	29	110	40.9	68	56.2	43	75.6	30	100	10
LTB-A 5 – 100	561 551 00	49.9		2221		542	10		20.6		32.9		48.3		67.9		93.2		125		166	
LTB-A 6 – 60	561 560 60	11.74		1564		372	11.3		23.7		38.5		56.7		79.6		108		144		188	
LTB-A 6 – 80	561 560 80	25.4	0.5	2086	0.5	497	15.1	900	31.7	280	51.4	150	75.9	92	107	57	145	38	194	28	253	10
LTB-A 6 – 120	561 561 20	78.3		3130		745	22.6		47.5		77.1		114		160		218		291		380	
LTB-A 7 – 80	561 570 80	27		2196		536	22.7		47.1		75.3		110		152		206		272		353	
LTB-A 7 – 100	561 571 00	52.2	0.5	2745	0.5	669	28.4	850	58.9	250	94.1	150	137	86	190	57	256	36	338	26	439	10
LTB-A 7 – 150	561 571 50	135		4063		991	42.1		87.8		141		206		286		385		508		658	
LTB-A 8 – 120	561 581 20	89.5		3442		840	72.9		139.5		209		289		390		519		685		898	
LTB-A 8 – 160	561 581 60	115.8		4617		1126	97.8		187.2		280		388		523		696		920		1206	
LTB-A 8 – 200	561 582 00	288	0.5	5772	0.5	1408	122.2	840	234	250	350	150	485	85	654	53	870	36	1150	24	1506	10
LTB-A 8 – 240	561 582 40	605		6919		1688	146.5		281		420		582		784		1044		1379		1807	
LTB-A 8 – 320	561 583 20	1677		9231		2252	195.4		374		560		776		1046		1393		1840		2411	

GUMMIFEDERELEMENT TYP LTB-A 9-12

RUBBER SUSPENSION UNIT TYPE LTB-A 9-12

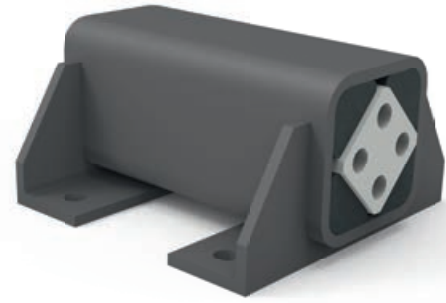

RESATEC GUMMIFEDERELEMENT TYP LTB-A:

Ab Typ LTB-A 8 sind im Innenprofil Gewinde vorhanden. Die Befestigungsflansche sind nach genormten Massen geschweisst, können jedoch auch nach Kundenvorgabe geformt und positioniert werden. Das Element wird durch die vorhandenen Befestigungslöcher im Flansch direkt an gewünschter Position verschraubt. Für wechselseitige Auslenkung über die Element-Nulllage geeignet.

RESATEC RUBBER SUSPENSION UNIT TYPE LTB-A:

There are threads in the inner profile starting from type LTB-A 8. The mounting flanges are welded according to standardized dimensions, but can also be designed and positioned according to customer specifications. The element is bolted directly to the desired position through the existing mounting holes in the flange. Suitable for alternating deflection over the element zero position.

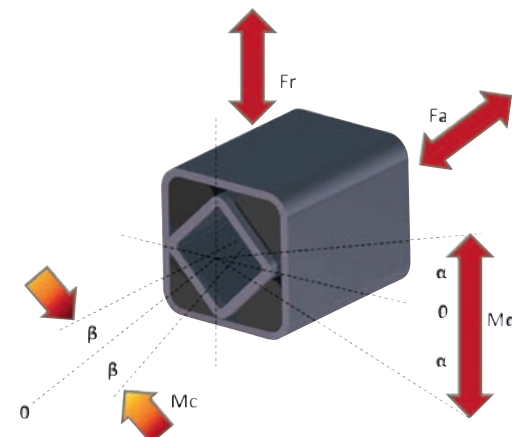
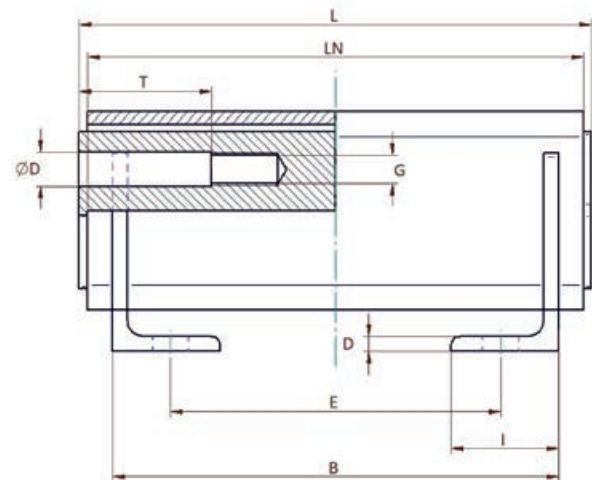
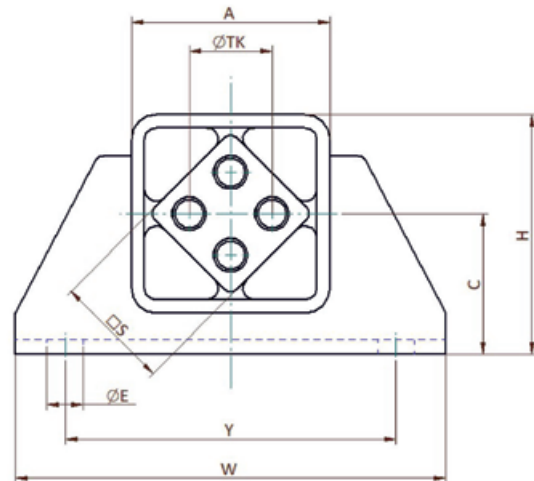

Abmasse/Material/dimensions/material

Typ type	Art. Nr. art. no.	A	B	C	D	øD	E	øE	G	H	I	L	LN	□S	T	øTk	W	Y	Gewicht weight	Verfügbarkeit availability
																			kg	am Lager on stock
LTB-A 9 – 150	561 591 50		130				60	18	M16 × 40			160	150						8.8	Lieferzeit auf Anfrage/delivery time on request Preis auf Anfrage/prices on request
LTB-A 9 – 200	561 592 00	100	170	65	8	16.5	100	18	M16 × 40	115	60	210	200	60	50	45	220	160	11.2	
LTB-A 9 – 300	561 593 00		270				200		M16 × 40			310	300						15.9	
LTB-A 10 – 200	561 510 20		170				100	22	M20 × 40			210	200						17.2	
LTB-A 10 – 300	561 510 30	120	270	80	9	20.5	200	22	M20 × 40	140	65	310	300	70	50	50	50	260	23.4	
LTB-A 10 – 400	561 510 40		370				300		M20 × 40			410	400						30.1	
LTB-A 11 – 200	561 511 20		170				80	22	M20 × 40			210	200						23.7	
LTB-A 11 – 300	561 511 30	140	270	85	10	20.5	180	22	M20 × 40	155	80	310	300	80	50	60	60	280	32.4	
LTB-A 11 – 400	561 511 40		370				280		M20 × 40			410	400						41.4	
LTB-A 12 – 250	561 512 25		220				110	26	M24 × 50			260	250						44	
LTB-A 12 – 400	561 512 40	170	370	110	12	25	260	26	M24 × 50	195	100	410	400	100	50	75	380	300	65.1	
LTB-A 12 – 500	561 512 50		470				360		M24 × 50			510	500						79.1	

Material

Aussenprofil: Stahl S235JR/pulverlackiert
Innenprofil: Stahl S235JR/ohne Beschichtung
Gummi: Basis auf SBR/Mischung Code C

Material

outer profile: Aluminium
core profile: steel S235JR/without coating
rubber: SBR based/mixture code C

Leistungsparameter/performance parameters

Typ type	Art. Nr. art. no.	MC @ β % ± 1°	Drehmoment und max. Erregerfrequenz bei Winkel α Torque and max. excitation frequency at angle α																			
			Radial				Axial															
			Federweg deflection	Belastung load	Federweg deflection	Belastung load	α +/- 4°	α +/- 8°	α +/- 12°	α +/- 16°	α +/- 20°	α +/- 24°	α +/- 28°	α +/- 32°								
Nm	Sr mm	Fr N	Sa mm	Fa N	Nm	min ⁻¹	Nm	min ⁻¹	Nm	min ⁻¹	Nm	min ⁻¹	Nm	min ⁻¹	Nm	min ⁻¹	Nm	min ⁻¹				
LTB-A 9 – 150	561 591 50	107		5 160		1 613	61.6	800	130	214	325	472	666	916	1 233							
LTB-A 9 – 200	561 592 00	296	1	6 880	1	2 150	82.1		173	250	285	130	433	82	629	50	887	38	1 221	23	1 643	10
LTB-A 9 – 300	561 593 00	1 065		10 417		3 255	124		273	464	714	1 042	1 463	1 995	2 657							
LTB-A 10 – 200	561 510 20	315		8 334		2 315	125	740	284	487	742	1 058	1 445	1 912	2 467							
LTB-A 10 – 300	561 510 30	1 350	1	11 654	1	3 237	175		392	230	672	130	1 035	78	1 499	48	2 085	33	2 812	23	3 700	10
LTB-A 10 – 400	561 510 40	2 475		18 024		5 007	270		577	965	1 475	2 151	3 036	4 173	5 604							
LTB-A 11 – 200	561 511 20	904		10 281		2 570	187	685	401	659	978	1 373	1 863	2 463	3 190							
LTB-A 11 – 300	561 511 30	1 993	1	15 422	1	3 855	281		602	210	989	130	1 467	73	2 060	43	2 794	28	3 694	23	4 784	10
LTB-A 11 – 400	561 511 40	6 115		20 550		5 138	375		816	1 352	2 013	2 829	3 828	5 039	6 493							
LTB-A 12 – 250	561 512 25	1 350		20 458		4 092	405		829	1 337	1 993	2 863	4 012	5 503	7 402							
LTB-A 12 – 400	561 512 40	4 838	1	32 735	1	6 547	648	620	1 326	190	2 139	110	3 189	63	4 581	38	6 419	28	8 805	18	11 843	10
LTB-A 12 – 500	561 512 50	9 000		40 919		8 184	810		1 658	2 674	3 987	5 727	8 024	11 007	14 805							

GUMMIFEDERELEMENT TYP LTB-C

RUBBER SUSPENSION UNIT TYPE LTB-C



RESATEC GUMMIFEDERELEMENT TYP LTB-C:

Das Innenprofil Typ C ermöglicht die Befestigung mit zentraler Schraube. Es sind Schrauben der Qualität 8,8 zu verwenden. Das Aussengehäuse kann durch die Befestigungslöcher in der Flanschartie direkt mit Schrauben der Qualität 8,8 befestigt werden. Für wechselseitige Auslenkung bis $\pm 10^\circ$ geeignet.

RESATEC RUBBER SUSPENSION UNIT TYPE LTB-C:

The inner profile type C enables fastening with central screw. Screws of quality 8.8 must be used. The outer housing can be fastened directly with quality 8.8 screws through the fastening holes in the flange section. Suitable for alternating deflection up to $\pm 10^\circ$.

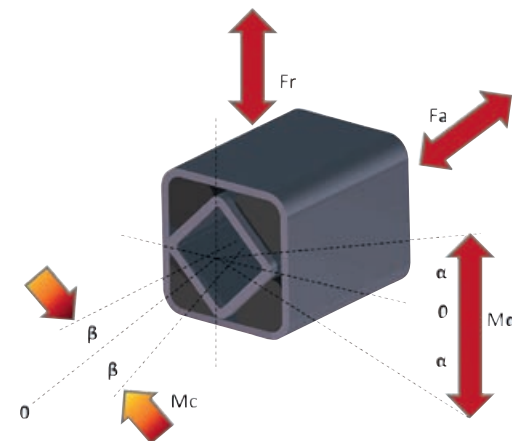
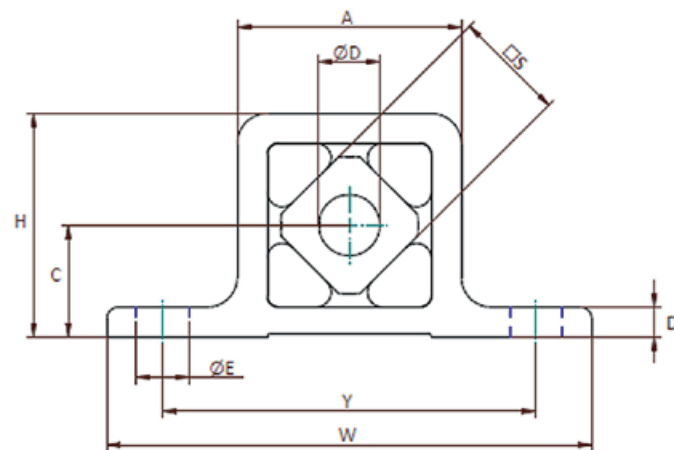

Abmasse/Material/dimensions/material

Typ type	Art. Nr. art. no.	A	W	H	C	D	S	LN	L	øD	E	øE	Y	Gewicht weight	Material		
															Außenprofil outer profile	Innenprofil core profile	Gummi rubber
LTB-C 5 – 40	561 650 40								40	45	–			0.21	Aluminium	Aluminium	Gummi Basis auf SBR /Mischung Code C SBR based/mixture code C
LTB-C 5 – 60	561 650 60	49	105	50	25.5	5	27	60	65	16	–	11	80	0.32			
LTB-C 5 – 100	561 651 00							100	105		60			0.51			
LTB-C 6 – 60	561 660 60							60	70		–			0.58	Aluminium	Aluminium	Gummi Basis auf SBR /Mischung Code C SBR based/mixture code C
LTB-C 6 – 80	561 660 80	66	125	67	34	6	38	80	90	20	40	13	100	0.74			
LTB-C 6 – 120	561 661 20							120	130		80			1.12			

Leistungsparameter/performance parameters

Typ type	Art. Nr. art. no.	MC @ β ±1°	Radial		Axial		Drehmoment und max. Erregerfrequenz bei Winkel α Torque and max. excitation frequency at angle α															
			Federweg deflection	Belastung load	Federweg deflection	Belastung load	α ±4°	α ±8°	α ±12°	α ±16°	α ±20°	α ±24°	α ±28°	α ±32°								
			Nm	Sr mm	Fr N	Sa mm	Fa N	Nm min ⁻¹	Nm min ⁻¹	Nm min ⁻¹	Nm min ⁻¹	Nm min ⁻¹	Nm min ⁻¹	Nm min ⁻¹	Nm min ⁻¹							
LTB-C 5 – 40	561 650 40	3.99		888		217	4.01	8.22	13.1	19.2	27	37	49.7	65.5								
LTB-C 5 – 60	561 650 60	12.01	0.5	1333	0.5	325	6.02	990	12.4	300	19.8	170	29	110	40.9	68	56.2	43	75.6	30	100	10
LTB-C 5 – 100	561 651 00	49.9		2221		542	10	20.6	32.9	48.3	67.9	93.2	125	166								
LTB-C 6 – 60	561 660 60	11.74		1564		372	11.3	23.7	38.5	56.7	79.6	108	144	188								
LTB-C 6 – 80	561 660 80	25.4	0.5	2086	0.5	497	15.1	900	31.7	280	51.4	150	75.9	92	107	57	145	38	194	28	253	10
LTB-C 6 – 120	561 661 20	78.3		3130		745	22.6	47.5	77.1	114	160	218	291	380								

GUMMIFEDERELEMENT TYP LTB-S

RUBBER SUSPENSION UNIT TYPE LTB-S



RESATEC GUMMIFEDERELEMENT TYP LTB-S:

Das Innenprofil Typ S ermöglicht eine Steckverbindung. Die Einstecktiefe des gesteckten Vierkantes soll mindestens dem 1,8-fachen des Materialquerschnittes (Mass S) entsprechen. Als Vierkant soll ein blanker Stahl mit der Toleranz h11 und facettierten Kanten verwendet werden. Das Aussengehäuse kann durch die Befestigungslöcher in der Flanschartie direkt mit Schrauben der Qualität 8,8 befestigt werden. Eine wechselseitige Auslenkung über die Element-Nulllage ist nicht möglich.

RESATEC RUBBER SUSPENSION UNIT TYPE LTB-S:

The inner profile type S enables a plug-in connection. The insertion depth of the inserted square should be at least 1.8 times the material cross-section (dimension S). The square should be made of bright steel with tolerance h11 and faceted edges. The outer housing can be fastened directly with quality 8.8 screws through the fastening holes in the flange section. An alternating deflection over the element zero position is not possible.

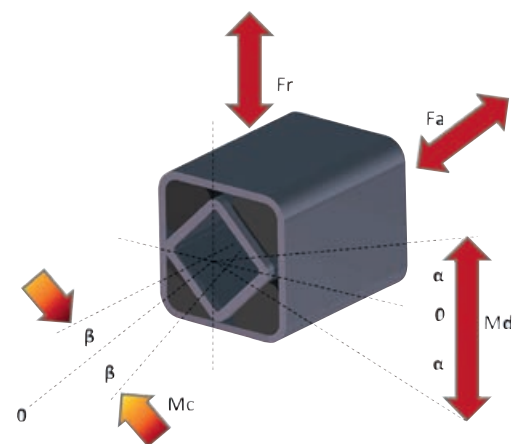
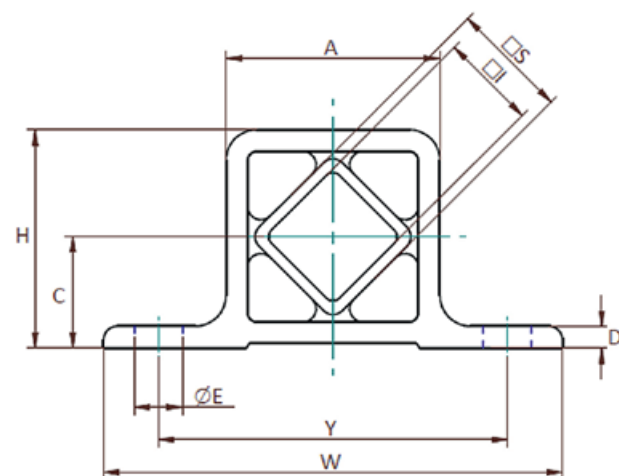

Abmasse/Material/dimensions/material

Typ type	Art. Nr. art. no.	A	C	D	E	øE	øF	H	øI	L	LN	øS	W	Y	Gewicht weight kg	Material		
																Außenprofil outer profile	Innenrohr/core square tube	Gummi rubber
LTB-S 3 – 40	561 430 40	27	15	4	–	7	–	30	11	45	40	15	65	50	2.18	SINT-C 40		
LTB-S 5 – 40	561 450 40				–					45	40				0.24	Aluminium	Stahl S235JR/galvanisch verzinkt steel S235JR/galvanized	Basis auf SBR/Mischung Code C SBR based/mixture code C
LTB-S 5 – 60	561 450 60	49	25.5	5	–	11	–	50	22	65	60	27	105	80	0.35			
LTB-S 5 – 100	561 451 00				60					105	100				0.57			
LTB-S 6 – 60	561 460 60				–		–			70	60				0.65			
LTB-S 6 – 80	561 460 80	66	34	6	40	13		67	30	90	80	38	125	100	0.83			
LTB-S 6 – 120	561 461 20				80					130	120				1.24			
LTB-S 7 – 80	561 470 80				40		–			90	80				1.2			
LTB-S 7 – 100	561 471 00	80	38.4	8	65	13		77	35	110	100	45	145	115	1.49			
LTB-S 7 – 150	561 471 50				2×60					160	150				2.18			
LTB-S 8 – 120	561 481 20				60					130	120				2.55			
LTB-S 8 – 160	561 481 60				2×60					170	160				3.35			
LTB-S 8 – 200	561 482 00	80	45	13	2×70	17	38	90	40	210	200	50	170	130	4.23			
LTB-S 8 – 240	561 482 40				3×60					250	240				5.03			
LTB-S 8 – 320	561 483 20				4×60					330	320				6.78			

Leistungsparameter/performance parameters

Typ type	Art. Nr. art. no.	MC @ β ±1°	Radial		Axial		Drehmoment und max. Erregerfrequenz bei Winkel α Torque and max. excitation frequency at angle α																	
			Federweg deflection	Belastung load	Federweg deflection	Belastung load	α +/- 4°		α +/- 8°		α +/- 12°		α +/- 16°		α +/- 20°		α +/- 24°		α +/- 28°		α +/- 32°			
			Sr mm	Fr N	Sa mm	Fa N	Nm	min ⁻¹	Nm	min ⁻¹	Nm	min ⁻¹	Nm	min ⁻¹	Nm	min ⁻¹	Nm	min ⁻¹	Nm	min ⁻¹	Nm	min ⁻¹	Nm	min ⁻¹
LTB-S 3 – 40	561 430 40	2	0.25	343	0.25	111	1	1100	2.2	330	3.5	190	5.1	120	7	72	9.2	46	11.7	33	14.7	10		
LTB-S 5 – 40	561 450 40	3.99		888		217	4.01	8.22	13.1	19.2	27	37	49.7	65.5										
LTB-S 5 – 60	561 450 60	12.01	0.5	1333	0.5	325	6.02	900	12.4	300	19.8	29	110	40.9	68	56.2	43	75.6	30	100	10			
LTB-S 5 – 100	561 451 00	49.9		2221		542	10	20.6	32.9	48.3	67.9	93.2	125	166										
LTB-S 6 – 60	561 460 60	11.74		1564		372	11.3	23.7	38.5	56.7	79.6	108	144	188										
LTB-S 6 – 80	561 460 80	25.4	0.5	2086	0.5	497	15.1	900	31.7	280	51.4	150	75.9	92	107	57	145	38	194	28	253	10		
LTB-S 6 – 120	561 461 20	78.3		3130		745	22.6	47.5	77.1	114	160	218	291	380										
LTB-S 7 – 80	561 470 80	27		2196		536	22.7	47.1	75.3	110	152	206	272	353										
LTB-S 7 – 100	561 471 00	52.2	0.5	2745	0.5	669	28.4	850	58.9	250	94.1	150	137	86	190	57	256	36	338	26	439	10		
LTB-S 7 – 150	561 471 50	135		4063		991	42.1	87.8	141	206	286	385	508	658										
LTB-S 8 – 120	561 481 20	89.5		3442		840	72.9	139.5	209	289	390	519	685	898										
LTB-S 8 – 160	561 481 60	115.8		4617		1126	97.8	187.2	280	388	523	696	920	1206										
LTB-S 8 – 200	561 482 00	288	0.5	5772	0.5	1408	122.2	840	234	250	350	150	485	85	654	53	870	36	1150	24	1506	10		
LTB-S 8 – 240	561 482 40	605		6919		1688	146.5	281	420	582	784	1044	1379	1807										
LTB-S 8 – 320	561 483 20	1677		9231		2252	195.4	374	560	776	1046	1393	1840	2411										

GUMMIFEDERELEMENT TYP LTK-A

RUBBER SUSPENSION UNIT TYPE LTK-A



RESATEC GUMMIFEDERELEMENT TYP LTK-A:

Das Innenprofil Typ A ermöglicht die Befestigung mit Schrauben. Bis zum Typ LTK 7 sind durchgehende Schrauben der Qualität 8,8 zu verwenden. Ab dem Typ LTK 8 sind im Innenprofil Gewinde vorhanden. Eine weitere einfache Einbaumöglichkeit bietet der RESATEC *Montagewinkel Typ MA*. Aussen wird das Gummifederelement in eine Klemmfaust gesteckt oder mit der RESATEC *Montagebride CK* befestigt.

RUBBER SUSPENSION UNIT TYPE LTK-A:

The inner profile type A allows fastening with screws. Up to type LTK 7, screws of quality 8.8 must be used. From type LTK 8, there are threads in the inner profile. Another simple installation option is the RESATEC *mounting bracket type MA*. On the outside, the rubber spring element is inserted into a clamp or fastened with the RESATEC *mounting bracket type CK*.



PASSENDE MONTAGEHALTERUNG TYP CK/MA
SEITE 38

MATCHING MOUNTING BRACKET TYPE CK/MA
PAGE 38

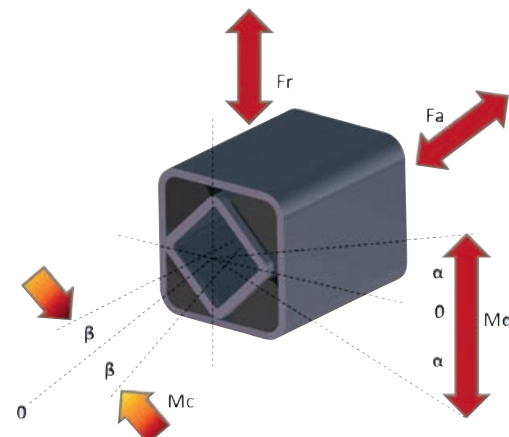
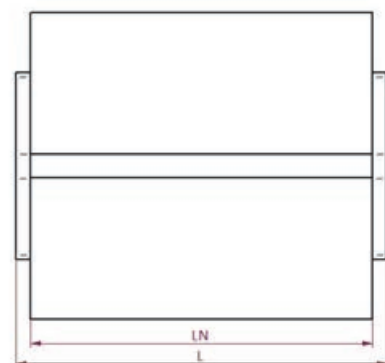
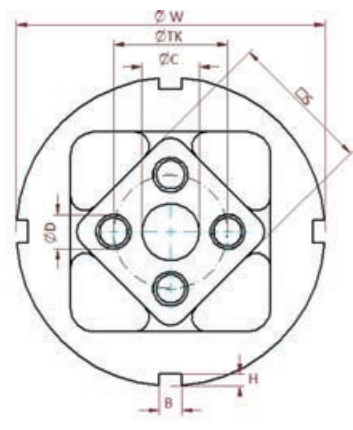

Abmasse/Material/dimensions/material

Typ type	Art. Nr. art. no.	$\varnothing W$	B	H	$\square S$	LN	L	$\varnothing TK$	$\varnothing D$	$\varnothing C$	Anzahl Briden no. of mounting brackets	Gewicht weight	Material					
													Aussenrohr outer square tube	Innenrohr/core square tube	Gummi rubber			
													Typ/type	MS	kg			
LTK-A 4 – 30	560 240 30					30	35				1	0.1	Stahl S235JR/galvanisch verzinkt steel S235JR/galvanized		Basis auf SBR/Mischung Code C SBR based/mixture code C			
LTK-A 4 – 50	560 240 50	45	5	2.5	18	50	55	12	6	–	1	0.16						
LTK-A 4 – 80	560 240 80					80	85				2	0.25						
LTK-A 5 – 40	560 250 40					40	45				1	0.25						
LTK-A 5 – 60	560 250 60	62	6	3	27	60	65	20	8	–	1	0.37						
LTK-A 5 – 100	560 251 00					100	105				2	0.61						
LTK-A 6 – 60	560 260 60					60	70				1	0.61						
LTK-A 6 – 80	560 260 80	80	3×7 + 1×8.5	3×4 + 1×7.5	38	80	90	25	10	–	2	0.8						
LTK-A 6 – 120	560 261 20					120	130				2	1.19						
LTK-A 7 – 80	560 270 80					80	90				1	1.08						
LTK-A 7 – 100	560 271 00	95	8	4	45	100	110	35	12	16.8	2	1.35						
LTK-A 7 – 150	560 271 50					150	160				2	2						
LTK-A 8 – 120	560 281 20					120	130		$\varnothing 10 + M12 \times 40$		2	2.28						
LTK-A 8 – 200	560 282 00	108	8	4	50	200	210	40		20.5	4	3.77						
LTK-A 8 – 300	560 283 00					300	310				5	5.63						

Leistungsparameter/performance parameters

Typ type	Art. Nr. art. no.	$MC @ \beta$ $\pm 1^\circ$	Radial		Axial		Drehmoment und max. Erregerfrequenz bei Winkel α Torque and max. excitation frequency at angle α															
			Federweg deflection	Belastung load	Federweg deflection	Belastung load	$\alpha \pm 4^\circ$	$\alpha \pm 8^\circ$	$\alpha \pm 12^\circ$	$\alpha \pm 16^\circ$	$\alpha \pm 20^\circ$	$\alpha \pm 24^\circ$	$\alpha \pm 28^\circ$	$\alpha \pm 32^\circ$								
			Sr mm	Fr N	Sa mm	Fa N	Nm	min ⁻¹	Nm	min ⁻¹	Nm	min ⁻¹	Nm	min ⁻¹	Nm	min ⁻¹	Nm	min ⁻¹	Nm	min ⁻¹		
LTK-A 4 – 30	560 240 30	1.51		386		92	1.6	3.37	5.38	7.71	10.4	13.6	17.4	21.8								
LTK-A 4 – 50	560 240 50	6.68	0.5	644	0.5	153	2.67	1050	5.64	330	9.07	190	13.1	110	17.9	72	23.6	46	30.4	33	38.4	10
LTK-A 4 – 80	560 240 80	26.9		1 030		245	4.27	9.01	14.5	20.8	28.3	37.3	47.8	60.2								
LTK-A 5 – 40	560 250 40	3.99		888		217	4.01	8.22	13.1	19.2	27	37	49.7	65.5								
LTK-A 5 – 60	560 250 60	12.01	0.5	1 333	0.5	325	6.02	990	12.4	300	19.8	170	29	110	40.9	68	56.2	43	75.4	30	100	10
LTK-A 5 – 100	560 251 00	49.9		2 221		542	10	20.6	32.9	48.3	67.9	93.2	125	166								
LTK-A 6 – 60	560 260 60	11.74		1 564		372	11.3	23.7	38.5	56.7	79.6	108	144	188								
LTK-A 6 – 80	560 260 80	25.4	0.5	2 086	0.5	497	15.1	900	31.7	280	51.4	150	75.9	92	107	57	145	38	194	28	253	10
LTK-A 6 – 120	560 261 20	78.4		3 130		745	22.6	47.5	77.1	114	160	218	291	380								
LTK-A 7 – 80	560 270 80	27		2 196		536	22.7	47.1	75.3	110	152	206	272	353								
LTK-A 7 – 100	560 271 00	52.2	0.5	2 745	0.5	669	28.4	850	58.9	250	94.1	150	137	86	190	57	256	36	338	26	439	10
LTK-A 7 – 150	560 271 50	135		4 063		991	42.1	87.8	141	206	286	385	508	658								
LTK-A 8 – 120	560 281 20	81.8		2 828		690	37.2	94.2	171	267	382	517	671	844								
LTK-A 8 – 200	560 282 00	263	0.5	5 712	0.5	1 393	74.6	840	184	250	329	150	509	85	723	53	971	36	1 254	24	1 570	10
LTK-A 8 – 300	560 283 00	1 355		8 654		2 110	183	350	525	776	980	1 305	1 725	2 260								

GUMMIFEDERELEMENT TYP LTK-C

RUBBER SUSPENSION UNIT TYPE LTK-C



RESATEC GUMMIFEDERELEMENT TYP LTK-C:
Das Innenprofil Typ C ermöglicht die Befestigung mit zentraler Schraube. Es sind Schrauben der Qualität 8,8 zu verwenden. Aussen wird das Gummifederelement in eine Klemmfaust gesteckt oder mit der RESATEC *Montagebride CK* befestigt.

RUBBER SUSPENSION UNIT TYPE TYPE LTK-C:
The inner profile type C enables fastening with central screw. Screws of quality 8.8 must be used. On the outside, the rubber spring element is inserted into a clamp or fastened with the *RESATEC mounting bracket type CK*.

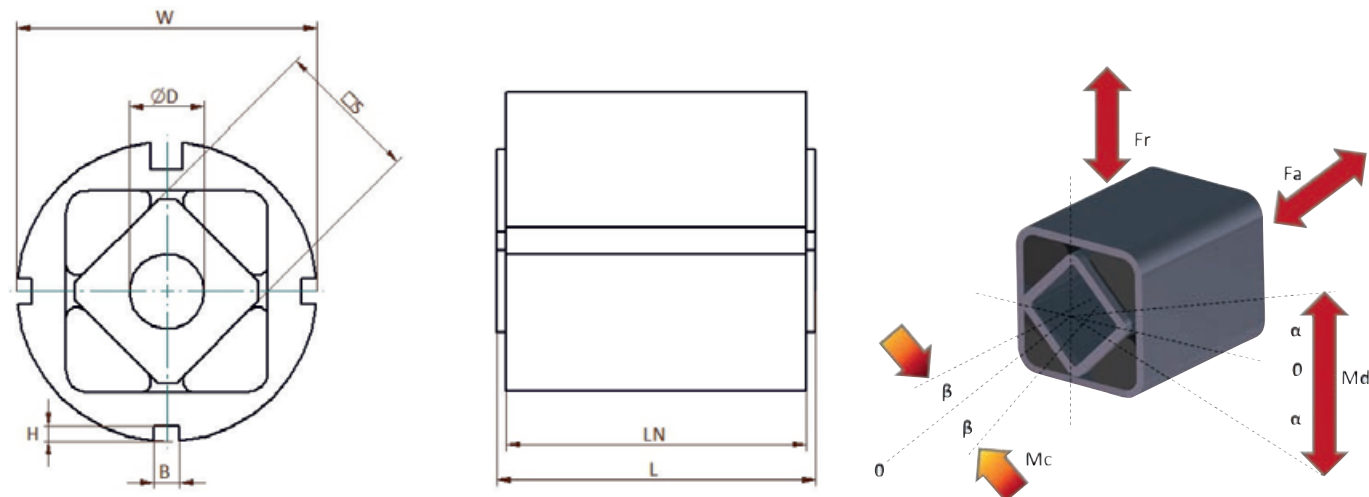

Abmasse/Material/dimensions/material

Typ type	Art. Nr. art. no.	øW mm	B mm	H mm	□S mm	LN mm	L mm	øD mm	Anzahl Briden no. of mounting brackets	Gewicht weight kg	Material		
											Aussenprofil outer profile	Innenprofil core profile	Gummi rubber
LTK-C 5 – 40	560 650 40					40	45	+0.5 0	1	0.25	Aluminium	Aluminium	Basis auf SBR/Mischung Code C SBR based/mixture code C
LTK-C 5 – 60	560 650 60	62	6	3	27	60	65	16	1	0.37			
LTK-C 5 – 100	560 651 00					100	105		2	0.61			
LTK-C 6 – 60	560 660 60	80	3×7 + 1×8.5	3×4 + 1×7.5	38	60	70	20	1	0.61	Aluminium	Aluminium	Basis auf SBR/Mischung Code C SBR based/mixture code C
LTK-C 6 – 80	560 660 80					80	90		2	0.8			
LTK-C 6 – 120	560 661 20					120	130		2	1.19			

Leistungsparameter/performance parameters

Typ type	Art. Nr. art. no.	MC @ β +/-1°	Radial		Axial		Drehmoment und max. Erregerfrequenz bei Winkel α Torque and max. excitation frequency at angle α															
			Federweg deflection	Belastung load	Federweg deflection	Belastung load	α +/- 4°		α +/- 8°		α +/- 12°		α +/- 16°		α +/- 20°		α +/- 24°		α +/- 28°		α +/- 32°	
			Sr mm	Fr N	Sa mm	Fa N	Nm	min ⁻¹	Nm	min ⁻¹	Nm	min ⁻¹	Nm	min ⁻¹	Nm	min ⁻¹	Nm	min ⁻¹	Nm	min ⁻¹	Nm	min ⁻¹
LTK-C 5 – 40	560 650 40	3.99		888		217	4.01		8.22		13.1	19.2	27	37	49.7	65.5						
LTK-C 5 – 60	560 650 60	12.01	0.5	1333	0.5	325	6.02	990	12.4	300	19.8	170	29	110	40.9	68	56.2	43	75.6	30	100	10
LTK-C 5 – 100	560 651 00	49.9		2221		542	10		20.6		32.9	48.3	67.9	93.2	125	166						
LTK-C 6 – 60	560 660 60	11.74		1564		372	11.3		23.7		38.5	56.7	79.6	108	144	188						
LTK-C 6 – 80	560 660 80	25.4	0.5	2086	0.5	497	15.1	900	31.7	280	51.4	150	75.9	92	107	57	145	38	194	28	253	10
LTK-C 6 – 120	560 661 20	78.3		3130		745	22.6		47.5		77.1	114	160	218	291	380						

GUMMIFEDERELEMENT TYP LTK-S

RUBBER SUSPENSION UNIT TYPE LTK-S



RESATEC GUMMIFEDERELEMENT TYP LTK-S:
Das Innenprofil Typ S ermöglicht eine Steckverbindung. Die Einstecktiefe des gesteckten Vierkantes soll mindestens dem 1,8-fachen des Materialquerschnittes (Mass S) entsprechen. Als Vierkant soll ein blanker Stahl mit der Toleranz h11 und facettierten Kanten verwendet werden. Aussen wird das Gummifederelement in eine Klemmfaust gesteckt oder mit der RESATEC *Montagebride CK* befestigt.

RESATEC RUBBER SUSPENSION UNIT TYPE LTK-S:
The inner profile TYPE S enables a plug-in connection. The insertion depth of the inserted square should be at least 1.8 times the material cross-section (dimension S). The square should be made of bright steel with tolerance h11 and faceted edges. On the outside, the rubber spring element is inserted into a clamping fist or fastened with the RESATEC *clamp mounting Type CK*.



PASSENDEN MONTAGEHALTERUNG TYP CK
SEITE 38

MATCHING MOUNTING BRACKET TYPE MS
PAGE 38

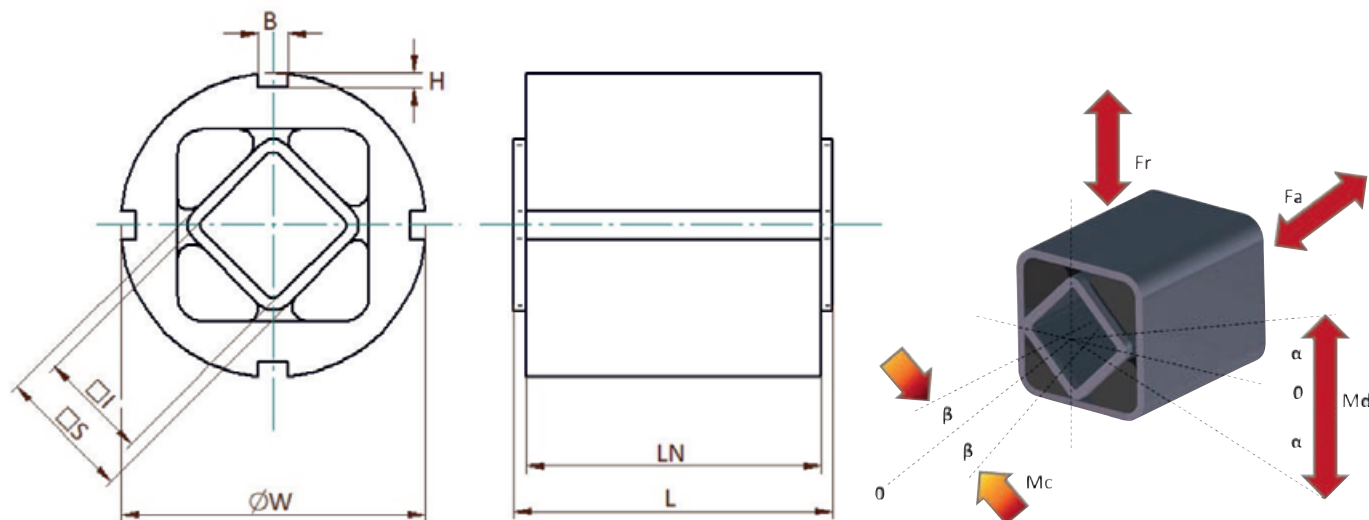

Abmasse/Material/dimensions/material

Typ type	Art. Nr. art. no.	øW	B	H	□S	LN	L	□I	Anzahl Briden no. of mounting brackets	Gewicht weight	Material			
											Aussenprofil outer profile	Innenrohr core square tube	Gummi rubber	
LTK-S 4 – 30	560 340 30					30	35		1	0.11	Aluminium	Stahl S235JR/galvanisch verzinkt steel S235JR/galvanized	Basis auf SBR/Mischung Code C SBR based/mixture code C	
LTK-S 4 – 50	560 340 50	45	5	2.5	18	50	55	12	1	0.18				
LTK-S 4 – 80	560 340 80					80	85		2	0.28				
LTK-S 5 – 40	560 350 40					40	45		1	0.27				
LTK-S 5 – 60	560 350 60	62	6	3	27	60	65	22	1	0.4				
LTK-S 5 – 100	560 351 00					100	105		2	0.66				
LTK-S 6 – 60	560 360 60		3×7 + 1×8.5	3×4 + 1×7.5		60	70		1	0.68				
LTK-S 6 – 80	560 360 80	80				38	80	90	30	2				0.89
LTK-S 6 – 120	560 361 20					120	130		2	1.31				
LTK-S 7 – 80	560 370 80					80	90		1	1.33				
LTK-S 7 – 100	560 371 00	95	8	4	45	100	110	35	2	1.64				
LTK-S 7 – 150	560 371 50					150	160		2	2.43				
LTK-S 8 – 120	560 381 20					120	130		2	2.55				
LTK-S 8 – 200	560 382 00	108	8	4	50	200	210	40	4	4.21				
LTK-S 8 – 300	560 383 00					300	310		5	6.28				

Leistungsparameter/performance parameters

Typ type	Art. Nr. art. no.	MC @ β +/- 1°	Radial		Axial		Drehmoment und max. Erregerfrequenz bei Winkel α Torque and max. excitation frequency at angle α															
			Federweg deflection	Belastung load	Federweg deflection	Belastung load	α +/- 4°	α +/- 8°	α +/- 12°	α +/- 16°	α +/- 20°	α +/- 24°	α +/- 28°	α +/- 32°								
			Nm	Sr mm	Fr N	Sa mm	Fa N	Nm min ⁻¹	Nm min ⁻¹	Nm min ⁻¹	Nm min ⁻¹	Nm min ⁻¹	Nm min ⁻¹	Nm min ⁻¹	Nm min ⁻¹							
LTK-S 4 – 30	560 340 30	1.51		386		92	1.6	3.37	5.38	7.71	10.4	13.6	17.4	21.8								
LTK-S 4 – 50	560 340 50	6.68	0.5	644	0.5	153	2.67	1050	5.64	330	9.07	190	13.1	110	17.9	72	23.6	46	30.4	33	38.4	10
LTK-S 4 – 80	560 340 80	26.90		1 030		245	4.27	9.01	14.5	20.8	28.3	37.3	47.8	60.2								
LTK-S 5 – 40	560 350 40	3.99		888		217	4.01	8.22	13.1	19.2	27	37	49.7	65.5								
LTK-S 5 – 60	560 350 60	12.01	0.5	1 333	0.5	325	6.02	990	12.4	300	19.8	170	29.0	110	40.9	68	56.2	43	75.4	30	100	10
LTK-S 5 – 100	560 351 00	49.9		2 221		542	10	20.6	32.9	48.3	67.9	93.2	125	166								
LTK-S 6 – 60	560 360 60	11.74		1 564		372	11.3	23.7	38.5	56.7	79.6	108	144	188								
LTK-S 6 – 80	560 360 80	25.4	0.5	2 086	0.5	497	15.1	900	31.7	280	51.4	150	75.9	92	107	57	145	38	194	28	253	10
LTK-S 6 – 120	560 361 20	78.4		3 130		745	22.6	47.5	77.1	114	160	218	291	380								
LTK-S 7 – 80	560 370 80	27.0		2 196		536	22.7	47.1	75.3	110	152	206	272	353								
LTK-S 7 – 100	560 371 00	52.2	0.5	2 745	0.5	669	28.4	850	58.9	250	94.1	150	137	86	190	57	256	36	338	26	439	10
LTK-S 7 – 150	560 371 50	135		4 063		991	42.1	87.8	141	206	286	385	508	658								
LTK-S 8 – 120	560 381 20	81.8		2 828		690	37.2	94.2	171	267	382	517	671	844								
LTK-S 8 – 200	560 382 00	263	0.5	5 712	0.5	1 393	74.6	840	184	250	329	150	509	85	723	53	971	36	1 254	24	1 570	10
LTK-S 8 – 300	560 383 00	1 355		8 654		2 110	183	350	525	776	980	1 305	1 725	2 260								

GUMMIFEDERELEMENT TYP LTD-A

RUBBER SUSPENSION UNIT TYPE LTD-A



RESATEC GUMMIFEDERELEMENT TYP LTD-A:

Das Innenprofil Typ A ermöglicht die Befestigung mit Schrauben. Bis zum Typ LTD-A 7 sind durchgehende Schrauben der Qualität 8,8 zu verwenden. Ab dem Typ LTD-A 8 sind im Innenprofil Gewinde vorhanden. Eine weitere einfache Adaption-Möglichkeit bietet der RESATEC-Montagewinkel Typ MA. Das Doppелеlement wird zur Realisierung von Serie- oder Parallelschaltungen verwendet.

RESATEC RUBBER SUSPENSION UNIT TYPE LTD-A:

The inner profile type A allows fastening with screws. Up to type LTD-A 7, screws of quality 8.8 must be used. From type LTD-A 8 there are threads in the inner profile. Another simple installation option is the RESATEC mounting bracket type MA. The double element is used for the realization of series or parallel connection.

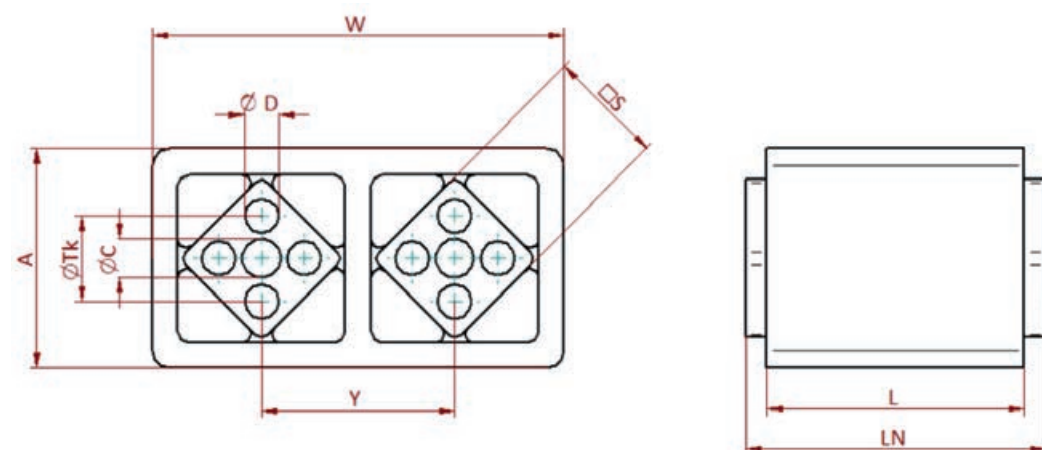
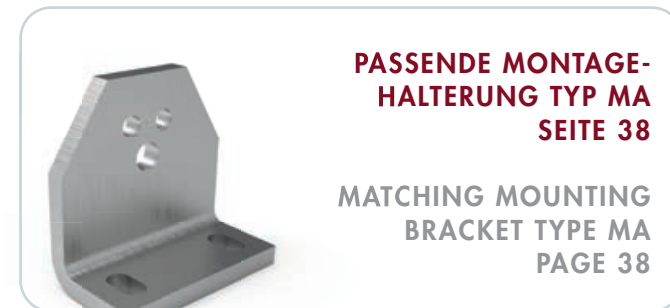

Abmasse/Material/dimensions/material

Typ type	Art. Nr. art. no.	A	øC	øD	G	L	LN	□S	T	øTK	W	Y	Gewicht weight	Material		
														Aussenprofil outer profile	Innenprofil core profile	Gummi rubber
LTD-A 5 – 40	562 550 40					45	40						0.34	Aluminium	Aluminium	Basis auf SBR/Mischung Code C SBR based/mixture code C
LTD-A 5 – 60	562 550 60	49	–	8	–	65	60	27	Durchgangsbohrung/ through hole	20	93	45	0.51			
LTD-A 5 – 100	562 551 00					105	100						0.83			
LTD-A 6 – 60	562 560 60					70	60						0.96			
LTD-A 6 – 80	562 560 80	66	–	10	–	90	80	38		25	126	60	1.25			
LTD-A 6 – 120	562 561 20					130	120						1.85			
LTD-A 7 – 80	562 570 80					90	80						1.77			
LTD-A 7 – 100	562 571 00	84	16.5	12	–	110	100	45		35	149	72	2.19			
LTD-A 7 – 150	562 571 50					160	150						3.25			
LTD-A 8 – 120	562 581 20					130	120						3.47			
LTD-A 8 – 160	562 581 60					170	160						4.61			
LTD-A 8 – 200	562 582 00	92.5	20.5	12.25	ø10 + M12 x 30	210	200	50	25	40	168	78	5.74			
LTD-A 8 – 240	562 582 40						250	240						6.88		
LTD-A 8 – 320	562 583 20						330	320						9.15		

Leistungsparameter/performance parameters

Typ type	Art. Nr. art. no.	MC @ β +/-1°	Radial		Axial		Drehmoment und max. Erregerfrequenz bei Winkel α Torque and max. excitation frequency at angle α															
			Federweg deflection	Belastung load	Federweg deflection	Belastung load	α +/- 4°	α +/- 8°	α +/- 12°	α +/- 16°	α +/- 20°	α +/- 24°	α +/- 28°	α +/- 32°								
			Nm	Sr mm	Fr N	Sa mm	Fa N	Nm	min ⁻¹	Nm	min ⁻¹	Nm	min ⁻¹	Nm	min ⁻¹	Nm	min ⁻¹	Nm	min ⁻¹	Nm	min ⁻¹	
LTD-A 5 – 40	562 550 40	3.99		888		217	4.01	8.22	13.1	19.2	27	37	49.7	65.5								
LTD-A 5 – 60	562 550 60	12.01	0.5	1 333	0.5	325	6.02	990	12.4	300	19.8	170	29	110	40.9	68	56.2	43	75.6	30	100	10
LTD-A 5 – 100	562 551 00	49.9		2 221		542	10	20.6	32.9	48.3	67.9	93.2	125	166								
LTD-A 6 – 60	562 560 60	11.74		1 564		372	11.3	23.7	38.5	56.7	79.6	108	144	188								
LTD-A 6 – 80	562 560 80	25.4	0.5	2 086	0.5	497	15.1	900	31.7	280	51.4	150	75.9	92	107	57	145	38	194	28	253	10
LTD-A 6 – 120	562 561 20	78.3		3 130		745	22.6	47.5	77.1	114	160	218	291	380								
LTD-A 7 – 80	562 570 80	27		2 196		536	22.7	47.1	75.3	110	152	206	272	353								
LTD-A 7 – 100	562 571 00	52.2	0.5	2 745	0.5	669	28.4	850	58.9	250	94.1	150	137	86	190	57	256	36	338	26	439	10
LTD-A 7 – 150	562 571 50	135		4 063		991	42.1	87.8	141	206	286	385	508	658								
LTD-A 8 – 120	562 581 20	89.5		3 442		840	72.9	139.5	209	289	390	519	685	898								
LTD-A 8 – 160	562 581 60	115.8		4 617		1 126	97.8	187.2	280	388	523	696	920	1 206								
LTD-A 8 – 200	562 582 00	288	0.5	5 772	0.5	1 408	122.2	840	234	250	350	150	485	85	654	53	870	36	1 150	24	1 506	10
LTD-A 8 – 240	562 582 40	605		6 919		1 688	146.5	281	420	582	784	1 044	1 379	1 807								
LTD-A 8 – 320	562 583 20	1 677		9 231		2 252	195.4	374	560	776	1 046	1 393	1 840	2 411								

GUMMIFEDERELEMENT TYP LTD-C

RUBBER SUSPENSION UNIT TYPE LTD-C

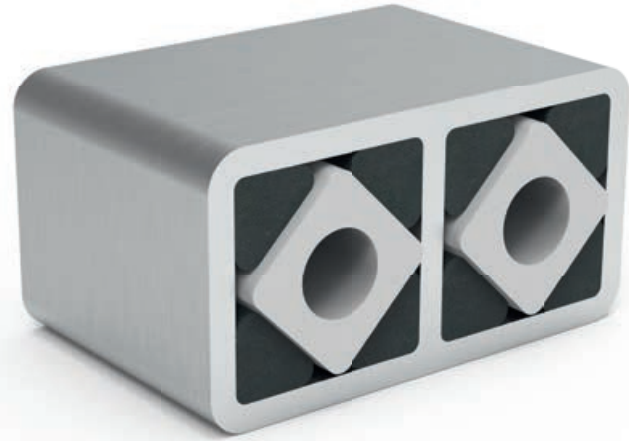

RESATEC GUMMIFEDERELEMENT TYP LTD-C:

Das Innenprofil Typ C ermöglicht die Befestigung mit zentraler Schraube. Es sind Schrauben der Qualität 8,8 zu verwenden. Das Doppелеlement wird zur Realisierung von Serie- oder Parallelschaltungen verwendet. Nur auf Anfrage verfügbar.

RESATEC RUBBER SUSPENSION UNIT TYPE LTD-C:

The inner profile type C enables fastening with central screw. Screws of quality 8.8 must be used. The double element is used for the realization of series or parallel circuits. Only available on request.

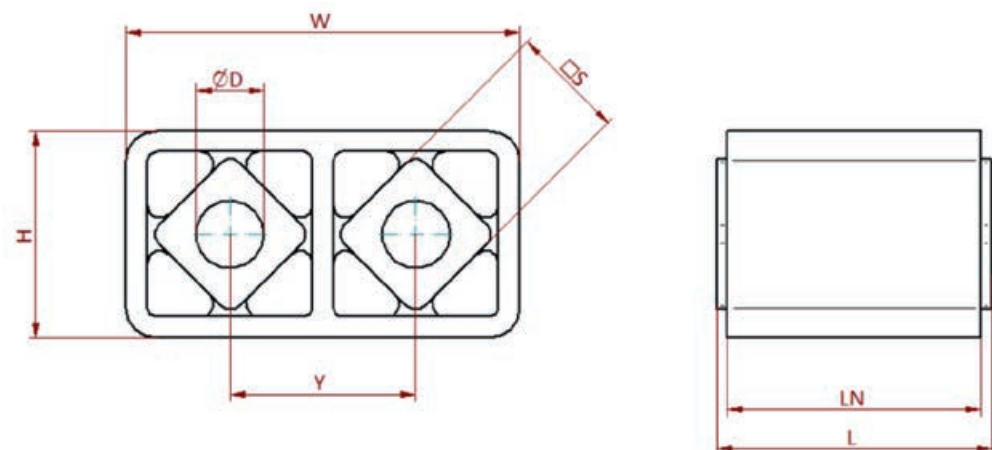

Abmasse/Material/dimensions/material

Typ type	Art. Nr. art. no.	øD +0,5 0 mm	H mm	L mm	LN mm	□S mm	W mm	Y mm	Gewicht weight kg	Material		
										Aussenprofil outer profile	Innenprofil core profile	Gummi rubber
LTD-C 5 – 40	562 650 40			45	40				0.34	Aluminium	Aluminium	Gummi rubber Basis auf SBR/Mischung Code C SBR based/mixture code C
LTD-C 5 – 60	562 650 60	16	49	65	60	27	93	45	0.50			
LTD-C 5 – 100	562 651 00			105	100				0.83			
LTD-C 6 – 60	562 660 60			70	60				0.95	Aluminium	Aluminium	Gummi rubber Basis auf SBR/Mischung Code C SBR based/mixture code C
LTD-C 6 – 80	562 660 80	20	66	90	80	38	126	60	1.25			
LTD-C 6 – 120	562 661 20			130	120				1.84			

Leistungsparameter/performance parameters

Typ type	Art. Nr. art. no.	MC @ β +/- 1° Nm	Radial		Axial		Drehmoment und max. Erregerfrequenz bei Winkel α Torque and max. excitation frequency at angle α															
			Federweg deflection load	Belastung load	Federweg deflection load	Belastung load	α +/- 4°	α +/- 8°	α +/- 12°	α +/- 16°	α +/- 20°	α +/- 24°	α +/- 28°	α +/- 32°								
			Sr mm	Fr N	Sa mm	Fa N	Nm min ⁻¹	Nm min ⁻¹	Nm min ⁻¹	Nm min ⁻¹	Nm min ⁻¹	Nm min ⁻¹	Nm min ⁻¹	Nm min ⁻¹								
LTD-C 5 – 40	562 650 40	3.99		888		217	4.01	8.22	13.1	19.2	27	37	49.7	65.5								
LTD-C 5 – 60	562 650 60	12.01	0.5	1'333	0.5	325	6.02	990	12.4	300	19.8	170	29	110	40.9	68	56.2	43	75.6	30	100	10
LTD-C 5 – 100	562 651 00	49.9		2'221		542	10	20.6	32.9	48.3	67.9	93.2	125	166								
LTD-C 6 – 60	562 660 60	11.74		1'564		372	11.3	23.7	38.5	56.7	79.6	108	144	188								
LTD-C 6 – 80	562 660 80	25.4	0.5	2'086	0.5	497	15.1	900	31.7	280	51.4	150	75.9	92	107	57	145	38	194	28	253	10
LTD-C 6 – 120	562 661 20	78.3		3'130		745	22.6	47.5	77.1	114	160	218	291	380								

GUMMIFEDERELEMENT TYP LTD-S

RUBBER SUSPENSION UNIT TYPE LTD-S

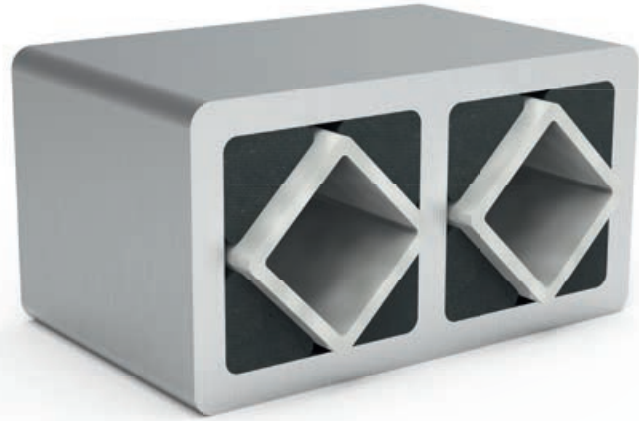

RESATEC GUMMIFEDERELEMENT TYP LTD-S:

Das Innenprofil Typ S ermöglicht eine Steckverbindung. Die Einstecktiefe des gesteckten Vierkantes soll mindestens dem 1,8-fachen des Materialquerschnittes (Mass S) entsprechen. Als Vierkant soll ein blanker Stahl mit der Toleranz h11 und facettierten Kanten verwendet werden. Das Doppelement wird zur Realisierung von Serie- oder Parallelschaltungen verwendet. Nur auf Anfrage verfügbar.

RESATEC RUBBER SUSPENSION UNIT TYPE LTD-S:

The inner profile type S enables a plug-in connection. The insertion depth of the inserted square should be at least 1.8 times the material cross-section (dimension S). The squares should be made of bright steel with tolerance h11 and faceted edges. The double element is used for the realization of series or parallel circuits. Only available on request.

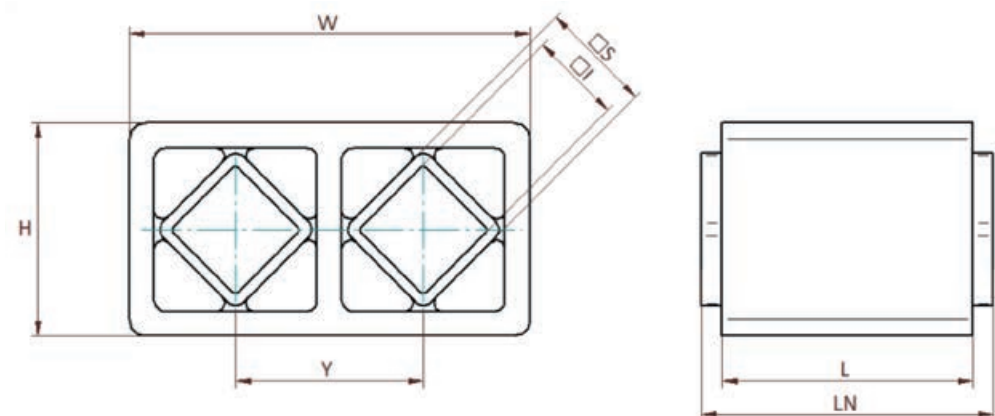

Abmasse/Material/dimensions/material

Typ type	Art. Nr. art. no.	W	H	□S	LN	L	□I	Y	Gewicht weight	Material		
		mm	mm	mm	mm	mm	mm	mm	kg	Außenprofil outer profile	Innenrohr core square tube	Gummi rubber
LTD-S 3 – 40	562 430 40	57	30	15	40	45	11	27	0.28	SINT-C 40		
LTD-S 5 – 40	562 450 40				40	45			0.39	Aluminium	Stahl S235JR/galvanisch verzinkt steel S235JR/galvanized	Basis auf SBR/Mischung Code C SBR based/mixture code C
LTD-S 5 – 60	562 450 60	93	49	27	60	65	22	45	0.58			
LTD-S 5 – 100	562 451 00				100	105			0.95			
LTD-S 6 – 60	562 460 60				60	70			1.09			
LTD-S 6 – 80	562 460 80	126	66	38	80	90	30	60	1.42			
LTD-S 6 – 120	562 461 20				120	130			2.10			
LTD-S 7 – 80	562 470 80				80	90			2.25			
LTD-S 7 – 100	562 471 00	149	84	45	100	110	35	72	2.78			
LTD-S 7 – 150	562 471 50				150	160			4.11			
LTD-S 8 – 120	562 481 20				120	130			4.05			
LTD-S 8 – 160	562 481 60				160	170			5.36			
LTD-S 8 – 200	562 482 00	168	92.5	50	200	210	40	78	6.66			
LTD-S 8 – 240	562 482 40				240	250			7.97			
LTD-S 8 – 320	562 483 20				320	330			10.57			

Leistungsparameter/performance parameters

Typ type	Art. Nr. art. no.	MC @ β ±1°	Radial		Axial		Drehmoment und max. Erregerfrequenz bei Winkel α Torque and max. excitation frequency at angle α															
			Federweg deflection	Belastung load	Federweg deflection	Belastung load	α +/- 4°		α +/- 8°		α +/- 12°		α +/- 16°		α +/- 20°		α +/- 24°		α +/- 28°		α +/- 32°	
			Sr mm	Fr N	Sa mm	Fa N	Nm	min ⁻¹	Nm	min ⁻¹	Nm	min ⁻¹	Nm	min ⁻¹	Nm	min ⁻¹	Nm	min ⁻¹	Nm	min ⁻¹	Nm	min ⁻¹
LTD-S 3 – 40	562 430 40	2	0.25	343	0.25	111	1	1000	2.2	330	3.50	190	5.1	120	7.00	72	9.2	46	11.7	33	14.7	10
LTD-S 5 – 40	562 450 40	3.99		888		217	4.01	8.22	13.1	19.2	27	37	49.7	65.5								
LTD-S 5 – 60	562 450 60	12.01	0.5	1333	0.5	325	6.02	990	12.4	300	19.8	170	29	110	40.9	68	56.2	43	75.6	30	100	10
LTD-S 5 – 100	562 451 00	49.9		2221		542	10.0	20.6	32.9	48.3	76.9	93.1	125	166								
LTD-S 6 – 60	562 460 60	11.74		1564		372	11.3	23.7	38.5	56.7	79.6	108	144	188								
LTD-S 6 – 80	562 460 80	25.4	0.5	2086	0.5	497	15.1	900	31.7	280	51.4	150	75.9	92	107	57	145	38	194	28	253	10
LTD-S 6 – 120	562 461 20	78.3		3130		745	22.6	47.5	77.1	114	160	218	291	380								
LTD-S 7 – 80	562 470 80	27		2196		536	22.7	47.1	75.3	110	152	206	272	353								
LTD-S 7 – 100	562 471 00	52.2	0.5	2745	0.5	669	28.4	850	58.9	250	94.1	150	137	86	190	57	256	36	388	26	439	10
LTD-S 7 – 150	562 471 50	135		4063		991	42.1	87.8	141	206	286	385	508	658								
LTD-S 8 – 120	562 481 20	89.5		3443		840	72.9	139.5	209	289	390	519	685	898								
LTD-S 8 – 160	562 481 60	115.8		4617		1126	97.8	187.2	280	388	523	696	920	1206								
LTD-S 8 – 200	562 482 00	288	0.5	5772	0.5	1408	122.2	840	234	250	350	150	485	85	654	53	870	36	1150	24	1506	10
LTD-S 8 – 240	562 482 40	605		6919		1688	146.5	281	420	582	784	1044	1379	1807								
LTD-S 8 – 320	562 483 20	1677		9231		2252	195.4	374	560	776	1046	1393	1840	2411								

MONTAGEWINKEL TYP MA

MOUNTING BRACKET TYPE MA

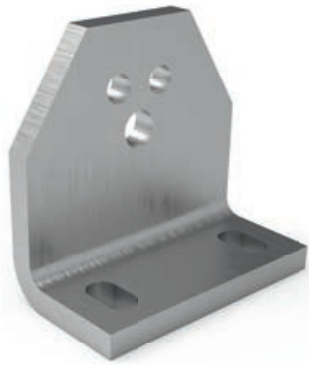

RESATEC MONTAGEBRIDE TYP MA:

Der Montagewinkel MA ermöglicht eine, einfache zur Grundfläche rechtwinklige Montage der RESATEC-Spannelemente LTA, LTK-A und LTD-A.

RESATEC MOUNTING BRACKET TYPE MA:

The MA mounting bracket enables easy mounting of the RESATEC LTA, LTK-A and LTD-A tensioners at right angles to the base surface.

MONTAGEBRIDE TYP CK/MS

MOUNTING BRACKET TYPE CK/MS



RESATEC MONTAGEBRIDE TYP CK:

Die RESATEC Montagebride Typ CK ermöglicht eine einfache Montage der REATEC-Gummifederelemente Typ LTK-S, LTK-A und LTK-C. Das Gummifederelement Typ LTK kann vor dem Festziehen der Schrauben in der Montagebride Typ CK frei gedreht werden. Dazu kann bis zu dem Typ CK 6 ein Hakenschlüssel nach DIN 1810 oder bei den grösseren Typen eine Gurtzange verwendet werden.

RESATEC MOUNTING BRACKET TYPE CK:

The RESATEC mounting bracket type CK allows easy mounting of the REATEC rubber spring elements type LTK-S, LTK-A and LTK-C. The rubber spring element type LTK can be rotated freely in the mounting bracket type CK before tightening the screws. For this purpose, a hook wrench according to DIN 1810 can be used up to type CK 6 or, in the case of the larger types, a strap wrench.

RESATEC MONTAGEBRIDE TYP MS:

Die RESATEC-Montagebride Typ MS ermöglicht eine einfache Montage der RESATEC-Gummifederelemente Typ LTS, LTA und LTC. Das Gummifederelement Typ LT kann vor dem Festziehen der Schrauben in der RESATEC-Montagebride Typ MS axial frei positioniert werden.

RESATEC CLAMP MOUNTING TYPE MS:

The RESATEC mounting bracket type MS allows easy mounting of the RESATEC rubber spring elements type LTS, LTA and LTC. The rubber spring element type LT can be freely positioned axially in the RESATEC mounting bracket type MS before tightening the screws.



Abmasse/Material/dimensions/material

Typ type	Art. Nr. art. no.	passend zu suitable for																	Gewicht weight	Material		
		øM	M	øA	A	øTK	T	U	V	X	Y	S	H	B	W	C	kg					
		TE	LT-A																			
MA 2-3	580 002 03	2	3	6.5	27	5.5	35	10	10	12	7	13	30	4	46	30	50	25	0.1	Stahl galvanisch verzinkt/ steel galvanised		
MA 3-4	580 003 04	3	4	8.5	34	6.5	44	123	10	14	7	13	40	6	58	32	60	30	0.2			
MA 4-5	580 004 05	4	5	10.5	45	8.5	55	20	10	16	9.5	16	50	6	75	38	70	40	0.3			
MA 5-6	580 005 06	5	6	12.5	75	10.5	75	25	12.5	21	11.5	22	65	8	98	52	90	58	0.7	Stahl mit Pulverlackierung/ steel with powder coating		
MA 6-7	580 006 07	6	7	16.5	66	12.5	85	35	15	21	14	24	80	8	116	55	110	56	0.9			
MA 7-8	580 007 08	7	8	20.5	80	12.5	110	40	20	26	18	30	100	10	140	66	140	68	1.8			

Abmasse/Material/dimensions/material

Typ type	Art. Nr. art. no.	øA	Y	øC	W	L	H	S	Gewicht weight	Material	
										kg	
MS 3	580 000 30	27	50	6.5	65	25	29	2	0.04	Stahl galvanisch verzinkt/ steel galvanised	
MS 4	580 000 40	32	60	8.5	80	30	34	3	0.09		
MS 5	580 000 50	45	80	10.5	105	35	48	3	0.16		
MS 6	580 000 60	60	100	12.5	125	40	65	5	0.29	Stahl mit Pulverlackierung/ steel with powder coating	
MS 7	580 000 70	75	115	12.5	145	45	80	5	0.45		

Abmasse/Material/dimensions/material

Typ type	Art. Nr. art. no.	øD	Y	øC	Z	W	L	H	S	B	Gewicht weight	Material	
												kg	
CK 4	580 000 44	45	68	8.5	25	90	30	49.5	2	9	0.15	Stahl galvanisch verzinkt/ steel galvanised	
CK 5	580 000 55	62	92	10.5	35	125	40	69	3	11.5	0.30		
CK 6	580 000 66	80	115	12.5	44	150	40	87	3	12.5	0.45		
CK 7	580 000 77	95	130	12.5	52.5	165	45	104	4	16	0.75	Stahl mit Pulverlackierung/ steel with powder coating	
CK 8	580 000 88	108	152	16.5	59	195	50	117	4	18	0.95		

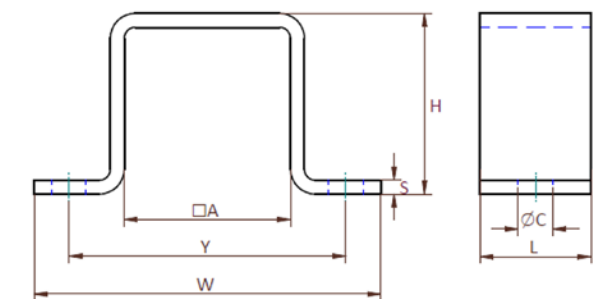
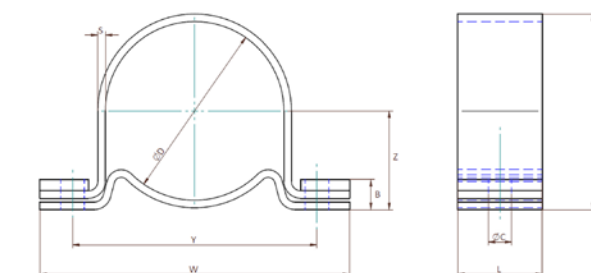
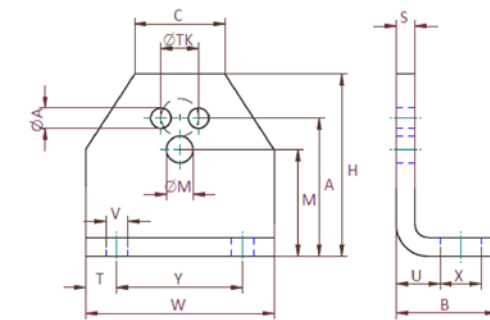



RESATEC
SWITZERLAND



RESATEC AG
ROSENWEG 1
CH-5037 MUHEN

+41 62 723 27 24
INFO@RESATEC.CH
WWW.RESATEC.CH